

- THEORY
- APPLICATIONS
- CIRCUITS

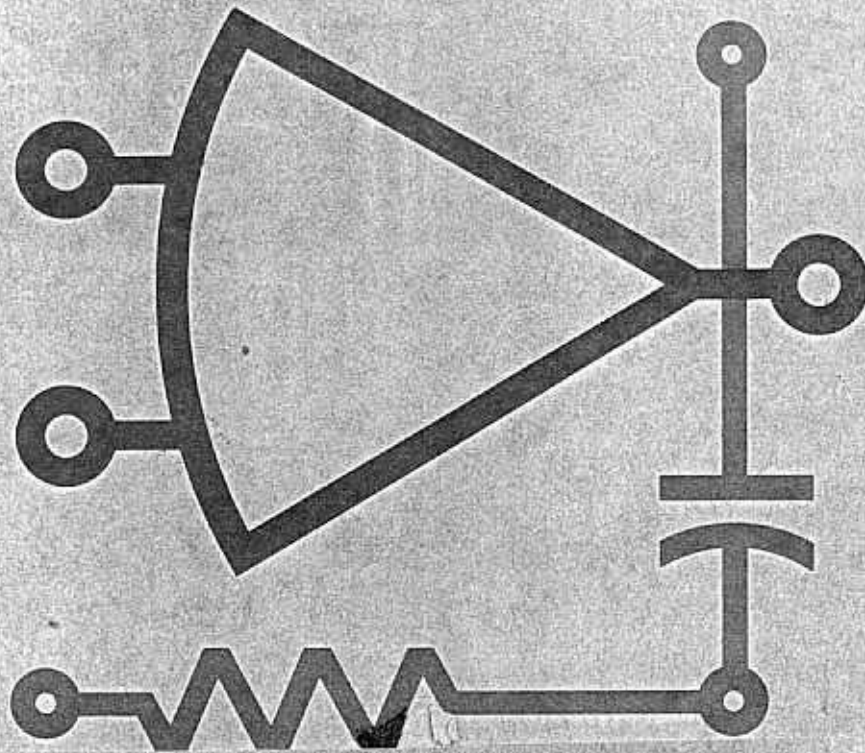

\$1



HANDBOOK OF OPERATIONAL AMPLIFIER
ACTIVE *RC* NETWORKS

SECOND EDITION
(First Printing)

HANDBOOK OF OPERATIONAL AMPLIFIER ACTIVE *RC* NETWORKS

This handbook has been compiled by
the Applications Engineering Section
of
Burr-Brown Research Corporation.
This department will welcome the opportunity
of offering its technical assistance in the
design of Active RC Networks or other
operational amplifier applications.

Printed in USA
© Burr-Brown Research Corporation

BURR-BROWN RESEARCH
CORPORATION
INTERNATIONAL AIRPORT
INDUSTRIAL PARK
TUCSON, ARIZONA 85706
CABLE ADDRESS BBRCORP

Copyright 1966

by

Burr-Brown Research Corporation

Circuit diagrams in this handbook are included to illustrate typical operational amplifier applications and are not intended as structural information. Although reasonable care has been taken in preparing this handbook, no responsibility is assumed for inaccuracies or consequences of using information presented. Furthermore, such information does not convey to the purchaser of the amplifier described any license under the patent rights of Burr-Brown Research Corporation or others.

PREFACE

Several years ago, the Applications Engineering Section of Burr-Brown prepared a Handbook of Operational Amplifier Applications describing the properties of operational amplifiers and some of their many uses. It was felt that such a handbook would be of interest and value not only to present users of operational amplifiers, but also to those who were considering new applications for them. The response with which this handbook was received was most rewarding. The original supply of books was quickly exhausted, and several additional printings also rapidly disappeared.

Recently, we have been receiving an ever increasing number of inquiries from our customers concerning the use of operational amplifiers in filtering applications. To satisfy these requests, we undertook the preparation of a second handbook, one on active RC networks. To aid us in this project we were fortunate to be able to secure the services of Dr. L. P. Huelsman of the University of Arizona, a recognized authority in this area. The result is this handbook. It contains both theoretical and applied treatments of the application of active RC networks to the more common filtering problems.

This booklet is intended for you, the user. If you should have any questions concerning the material in this handbook, or any other operational amplifier application, please do not hesitate to contact the Applications Engineering Section at Burr-Brown. We will be most happy to talk with you at any time.

Thomas R. Brown, Jr., President

FROM THE AUTHOR

Over the past decade, one of my primary interests has been the merging of the practical and theoretical aspects of the very fascinating subject of inductanceless filter realizations, or, as they are more popularly called, active RC networks. The researches performed by myself and others have indicated that such networks are not only practical, but in many applications, they are quite superior to their passive counterparts. Early in these investigations it became apparent that the operational amplifier provided a common basis linking many different theoretical approaches. Thus, when I was approached with the request to aid in the preparation of a handbook on this subject, I found it most appropriate that the request should come from a manufacturer of these devices. The result of our efforts is this handbook. I found the writing of it both challenging and entertaining. I hope that you, the reader, will find it both stimulating and of value as an introduction to a most important and interesting area of network theory, the area of active RC networks.

Any such book is naturally the result of the efforts and enthusiasm of many people. In particular I would like to acknowledge the most able technical and engineering assistance given by the Applications Engineering Section of Burr-Brown. Their background, knowledge, and experience in solving active network problems were of immeasurable assistance.

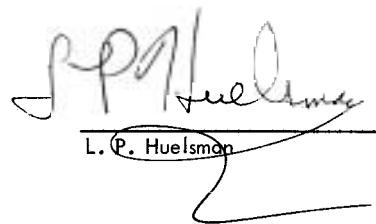

L. P. Huelsmen

TABLE OF CONTENTS

	Page
Preface	3
SECTION I - Active RC Network Theory	8
Chapter 1 - Introduction	9
Chapter 2 - The Infinite-Gain Single-Feedback Circuit	15
The Operational Amplifier	15
The Basic Single Feedback Circuit	16
The Voltage Transfer Function	18
Active Networks	20
Network Design	22
Conclusions	25
Chapter 3 - The Infinite-Gain Multiple-Feedback Circuit	27
The Basic Multiple Feedback Circuit	27
The Voltage Transfer Function	28
Network Design	29
Conclusions	33
Chapter 4 - The Controlled Source Circuit	35
The Voltage-Controlled Voltage Source	35
Network Design	37
Other Realizations with Voltage-Controlled Voltage Sources	42
Conclusions	44

	Page
Chapter 5 - The NIC in Active RC Circuits	45
The NIC (Negative-Immittance Converter)	45
A Realization for the INIC	47
Stability of the INIC	48
The Basic INIC Circuit	50
Network Design	51
Conclusions	55
Chapter 6 - Another Active Device - The Gyrator	57
Definition of a Gyrator	57
Properties of the Gyrator	58
A Gyrator Realization	59
Circuit Realizations	60
Conclusions	60
Chapter 7 - A Summary	63
SECTION II - Circuits	66
Introduction	67
Circuit No. 1 Single Feedback - Low Pass	68
Circuit No. 2 Single Feedback - High Pass	70
Circuit No. 3 Single Feedback - Band Pass	72
Circuit No. 4 Multiple Feedback - Low Pass	74
Circuit No. 5 Multiple Feedback - High Pass	76
Circuit No. 6 Multiple Feedback - Band Pass	78
Circuit No. 7 Controlled Source - Low Pass	80
Circuit No. 8 Controlled Source - High Pass	82
Circuit No. 9 Controlled Source - Band Pass	84

	Page
Circuit No. 10 INIC - Low Pass	86
Circuit No. 11 INIC - High Pass	88
Circuit No. 12 INIC - Band Pass	90
APPENDIX A - References	92
APPENDIX B - Describing Active Filters	95
APPENDIX C - Operational Amplifiers Specifications & Mechanical Data	97
- Active Filter Specifications	100
APPENDIX D - Reactance Chart	103

SECTION I

ACTIVE RC NETWORK THEORY

The subject of active RC networks is one which has attracted considerable attention in the past few years from network theorists. Many new active devices and many new techniques have been developed. Some of these techniques have been of great theoretical interest, but of little practical value. Others, however, offer great practicality and have great potential for everyday application. In writing this handbook, the goal has been to screen the large volume of literature on this subject, and present only those techniques which are of definite practical value to the working engineer. All of the realization schemes described in Chapters 2 through 5 have been proven on the bench, and full details on their implementation are given in the circuits section of this handbook. In addition, each of these techniques is described in the text, where some of the pertinent theoretical background is given. The reader who is interested in a more detailed theoretical treatment will find that the references listed in Appendix A will give him an excellent introduction into the considerable literature on this subject.

CHAPTER 1 INTRODUCTION



This is a handbook on active RC networks. The first question about this subject that one might ask is, "What is an active RC network?" The answer is simple. It is a collection of resistors, capacitors, and an active element (or elements). Viewed in another sense, it is a circuit without indu-

tors. Why leave out inductors? There are many reasons. First of all, the inductor is a relatively large and heavy element. This is especially true at frequencies in the audio range and below. Second, inductors generally have more dissipation associated with them than capacitors of similar size do. In other words, commercially available inductors are not nearly as "ideal" as commercially available capacitors usually are. If you have tried to use network synthesis techniques you have probably discovered that the dissipation (or resistance) associated with inductors can cause considerable difficulty. For these reasons (and a few others such as non-linearity, saturation, and cost) more and more interest is being shown in circuit design techniques which avoid the use of inductors, namely active RC networks.



Can active RC networks do everything that passive RLC networks can do? Yes, and more! They can have natural frequencies anywhere in the left half of the complex frequency (or "s") plane. They can function as oscillators; in other words they can have natural frequencies on the $j\omega$ axis. They can provide transformation ratios just like the coupled coils of a transformer do (however they can't provide the isolation). They can even provide perfect coupling and thus realize "ideal" transformers, which actual coupled coils cannot do. They can gyrate microfarads of capacitance into hundreds of henries of inductance, etc. There won't be space in this handbook to cover all of the things that active RC networks can do. Instead, we'll try to show you in detail how to use them to do some of your more common filtering tasks. If you are interested in more specialized applications, some references are given in Appendix A.



How does the tremendous capability of active RC networks come about? Certainly not from the passive elements, the resistors and capacitors. Taken by themselves, these elements can produce natural frequencies only on the negative real axis of the complex frequency plane, a relatively uninteresting region for most filtering applications. Active RC networks, on the other hand, can have natural frequencies anywhere

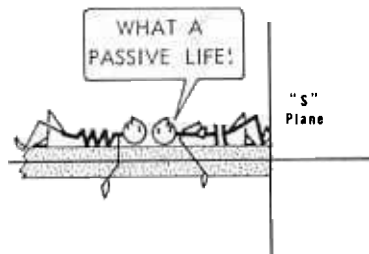

Natural frequencies for passive RC circuits

on the complex frequency plane. Right half plane natural frequencies, of course, are not useful because they signify unstable network behavior, so we'll just consider the usable active RC natural frequencies as being in the left half plane or on the $j\omega$ axis. Since it is the "active" element that gives

active RC networks their potentiality, let's briefly consider such elements in more detail.

There are several types of active elements that can be used in active RC networks. First, there is the ideal voltage amplifier of high gain. By "high" here we mean a gain in the order of at least 60 db. By "ideal"

we mean infinite input impedance and zero output impedance. The operational amplifier is an example of such an active element. Second, there is the ideal voltage amplifier of low gain. By "low" here we mean a gain in the order of 20 db or less. Such an element is sometimes referred to as a controlled source. Third, there is the NIC (negative-immittance converter, also sometimes referred to as a negative-impedance converter). This is a two-port device (a device with two sets of terminal pairs) with



the property that an impedance connected across one set of terminals appears as a negative impedance at the other set of terminals. Fourth, there is the gyrator, a device that converts capacitance to inductance and vice versa. An interesting point

to be noted here is that any of the last three types of active elements listed above can also be realized very simply and accurately with operational amplifiers. Thus, we see that the operational amplifier can be considered as a basic building block for constructing every type of active RC network. Many more details about the active elements

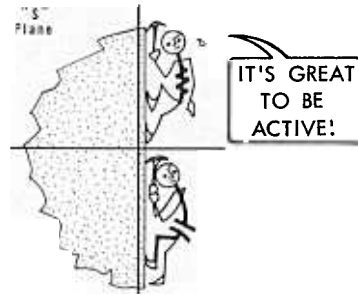

Stable natural frequencies for active RC circuits

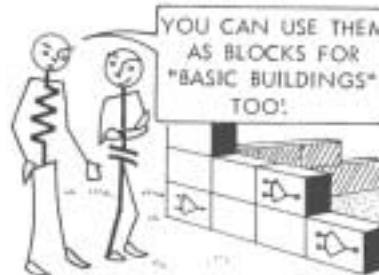

roduced above will be given in the sections that follow. The networks which use operational amplifiers to realize these active elements will also be discussed. First, however, let us say a few things about the operational amplifier

The modern differential input operational amplifier may be simply modeled as an ideal voltage amplifier of very low output impedance (we'll assume that it is zero), very high input impedance (we'll assume that it is infinite), and very high gain, with the property that the output voltage is proportional to the difference in the voltages applied to the two input terminals. An equivalent circuit for such a model is shown in Fig.

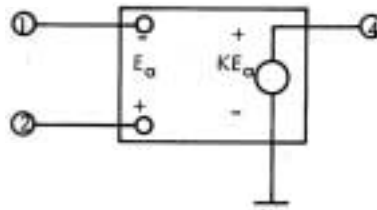

Fig. 1-1. Ideal model for an operational amplifier.

The circuit symbol that will be used in future discussions is shown with the same terminal numbers in Fig. 1-2.

As a result of the properties of the operational amplifier, when it is inserted

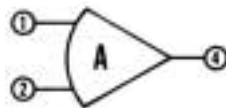

Fig. 1-2. Circuit symbol for an operational amplifier.

in circuit configurations, the voltage between the input terminals numbered 1 and 2 in Figs. 1-1 and 1-2 is driven to zero. Due to the high input impedance and zero voltage, the current into both of these terminals may be considered as zero. These two characteristics comprise the "virtual ground"

concept which is a basic tool for analyzing operational amplifier circuits. For more detailed information on the properties and characteristics of operational amplifiers, you should consult the "Handbook of Operational Amplifier Applications" which is available from Burr-Brown Research Corporation.

In the remainder of this handbook, we shall discuss in detail how the variou:

types of active elements introduced above may be used to produce the commonest types of network characteristics, namely, the low-pass, the high-pass, and the band-pass characteristic. We shall see that each of the active elements has its own advantages and disadvantages in the different circuit configurations. So, without more delay, let us start our investigation of active RC networks, a world without inductors.



This Page Intentionally Left Blank

CHAPTER 2

THE INFINITE-GAIN SINGLE-FEEDBACK CIRCUIT

The first active element that we shall consider for realizing active RC networks is the operational amplifier. In this chapter we shall investigate its use directly as an operational amplifier, in other words we shall not first modify it so that its characteristics approach those of some other active device. It may be helpful at this point to review briefly some of the characteristics of the operational amplifier. Those readers who are familiar with operational amplifiers may skip the next section without loss of continuity

The Operational Amplifier

In Fig. 2-1 we have shown a symbolic representation for an operational amplifier which defines the input voltages E_1 and E_2 and the output voltage E_o . The terminal numbers 1,

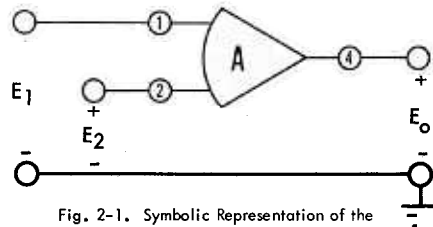

Fig. 2-1. Symbolic Representation of the Operational Amplifier

2, and 4 are standard markings on all Burr-Brown operational amplifiers. In terms of

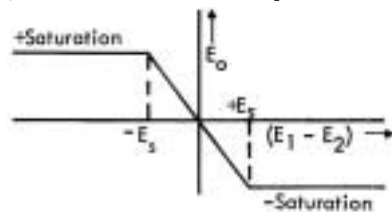

Fig. 2-2. Open-Loop DC Transfer Characteristic of the Operational Amplifier

these voltages we may plot a typical open-loop d-c transfer characteristic as shown in Fig. 2-2. From this figure we see that terminal 1 may be referred to as the "inverting" input terminal,

while terminal 2 may be referred to as the "non-inverting" input terminal. In a typical solid-state operational amplifier (for example, the Burr-Brown Model 3005/15) the magnitude of E_o is greater than 10 volts at saturation. The open-loop d-c gain of the amplifier is 100,000, so we see that the magnitude of E_s , the differential input voltage that produces saturation, is 0.1 millivolts. The open-loop frequency characteristic of a typical operational amplifier is shown in Fig. 2-3. The slope of the roll-off is less

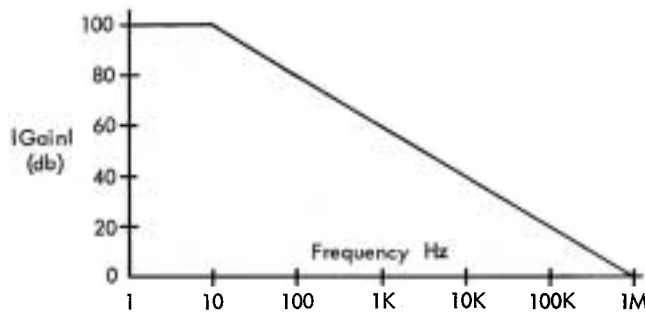

Fig. 2-3. Open-Loop Frequency Characteristic of a Typical Operational Amplifier

than 12 db/octave. The location of the break point is determined by a compensation network. In some operational amplifiers (such as the Burr-Brown Model 3005/15) this network is integral with the operational amplifier circuitry; in others, (such as the Burr-Brown Model 1509/15) it is external to the amplifier packaging, and thus may be readily changed. Stability considerations determine the proper choice of compensation network for a given circuit configuration; however, most operational amplifiers are compensated so as to provide adequate performance for the majority of circuit applications. For additional information on stability, compensation, or other general properties of operational amplifiers, the reader is referred to the "Handbook of Operational Amplifier Applications," published by Burr-Brown.

The Basic Single Feedback Circuit

The basic circuit that will be considered in this chapter consists of two passive networks, which we will refer to as network A and network B, and an operational

amplifier. Network A is connected between the input to the circuit and the input terminal of the operational amplifier. Network B is used as a feedback network from the output to the input of the operational amplifier. The circuit is shown in Fig. 2-4.

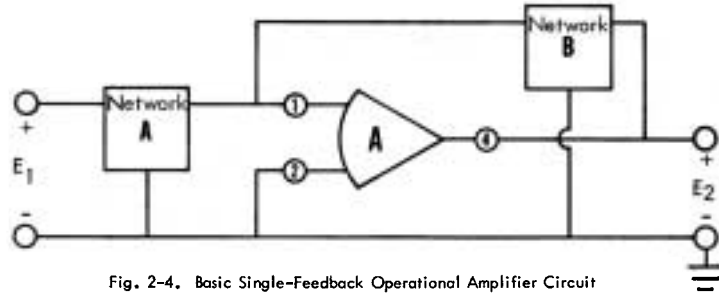

Fig. 2-4. Basic Single-Feedback Operational Amplifier Circuit

should be noted that the operational amplifier is used in an inverting configuration, i.e., with its non-inverting input terminal (terminal 2) grounded. We shall call this circuit an infinite-gain single-feedback circuit since the operational amplifier which is the active element normally has very high gain, and since the feedback around it is made to a single point.

To characterize the properties of the two passive networks, we shall use their y parameters. For network A we may define voltage and current variables as shown in Fig. 2-5. The relations between these variables and the y parameters of the network are

$$\begin{aligned} I_{1a} &= y_{11a}E_{1a} + y_{12a}E_{2a} \\ I_{2a} &= y_{12a}E_{1a} + y_{22a}E_{2a} \end{aligned} \quad (1)$$

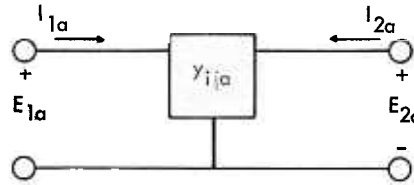

Fig. 2-5. The Port Variables for Network A

Similarly, for network B and the variables shown in Fig. 2-6, we may write

$$\begin{aligned} I_{1b} &= y_{11b}E_{1b} + y_{12b}E_{2b} \\ I_{2b} &= y_{12b}E_{1b} + y_{22b}E_{2b} \end{aligned} \quad (2)$$



Fig. 2-6. The Port Variables for Network B

All of the voltage and current variables and the y parameters defined in equations

(1) and (2) are functions of "s", the complex frequency variable

The Voltage Transfer Function

The basic network configuration for the infinite-gain single-feedback circuit has been redrawn in Fig. 2-7 to indicate the variables of the two passive networks ex-

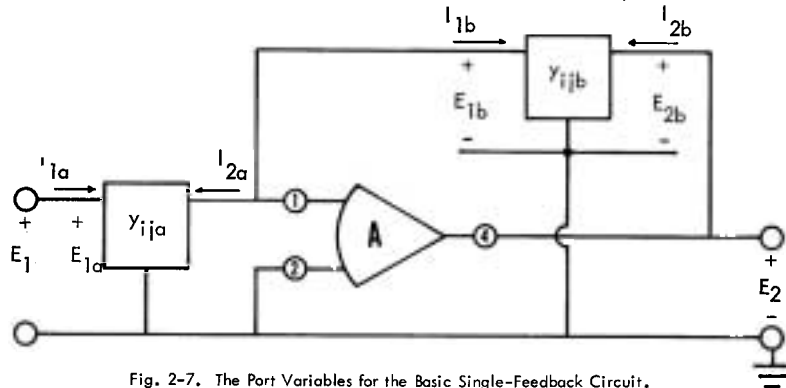

Fig. 2-7. The Port Variables for the Basic Single-Feedback Circuit.

plicitly. In Chapter 1, it was pointed out that due to the "virtual ground," the voltage between terminals 1 and 2 of the operational amplifier may be considered to be

Thus, the voltage E_{2a} shown in Fig. 2-7 is zero. From the second equation of (1), we see that under this condition $I_{2a} = y_{12a} E_{1a}$. In addition, since E_{1a} and E_1 are equal, we may write

$$I_{2a} = y_{12a} E_1 \quad (3)$$

Similarly, for network B, E_{1b} is zero, and $E_{2b} = E_2$. Thus we see that

$$I_{1b} = y_{12b} E_2 \quad (4)$$

The virtual ground concept also tells us that the current into terminal 1 of the operational amplifier is negligibly small. Thus we see that $I_{2a} = -I_{1b}$. We may now combine equations (3) and (4) to obtain

$$\frac{E_2}{E_1} = \frac{-Y_{12a}}{Y_{12b}}$$

This is the open-circuit voltage transfer function for the infinite-gain single-feedback active circuit configuration.

Let us examine the voltage transfer function given in equation (5) more closely. If networks A and B are passive RC networks, their natural frequencies will be on the negative real axis of the complex frequency plane. Let us assume that both of the passive networks have the same natural frequencies; then the denominators of the functions y_{12a} and y_{12b} will cancel and the locations of these natural frequencies will not affect the voltage transfer function of the overall network. The poles of the voltage transfer function of the active network configuration will then be determined solely by the zeros of the transfer admittance y_{12b} . Since a passive RC network can have the zeros of its transfer admittance anywhere on the complex frequency plane, this says that we can realize complex conjugate poles in our voltage transfer function. Such poles will, of course, be restricted to the left half of the complex frequency plane for reasons of stability. Similarly, the zeros of the voltage transfer function given in equation (5) will be determined by the zeros of y_{12a} , and therefore we can realize any desired real or complex conjugate zeros in our voltage transfer function. Thus we see that an infinite-gain single-feedback active RC network configuration can be used to realize almost any desired pole-zero configuration.

One other property of this circuit should be noted. Suppose that another network with transfer admittance y_{12c} is also connected to the input terminal of the operational amplifier. The connection is shown in Fig. 2-8, where the additional network is labeled as network C. The input voltages to networks A and C are E_{1a} and E_{1c} respectively. An analysis similar to the one made in the preceding paragraph shows that the output voltage E_2 for this circuit is given by the relation

$$E_2 = - \left[\frac{y_{12a}}{y_{12b}} E_{1a} + \frac{y_{12c}}{y_{12b}} E_{1c} \right] \quad (6)$$

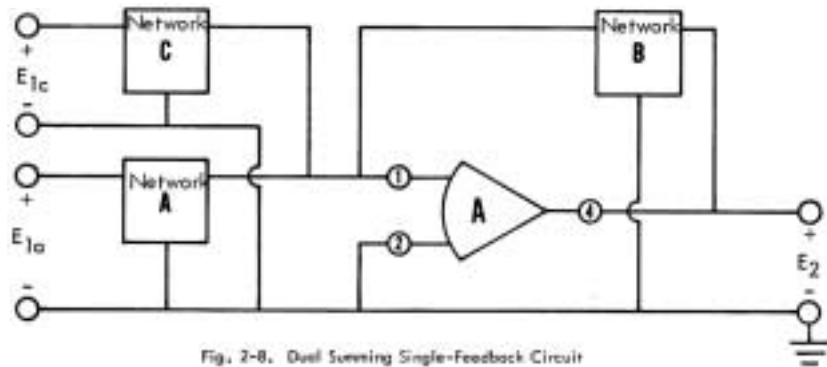

Thus we see that the infinite-gain single-feedback circuit configuration can also be used for summing signals from separate sources. This can be done without any interaction occurring between the sources.

The Passive Networks

In general, most filter designs require the use of complex conjugate poles. To produce these by the active RC technique described in this chapter, we thus require passive networks which have transfer admittances with complex conjugate zeros. There are several such network configurations, of which the two most common ones are the bridged-T network and the twin-T network. It is beyond the scope of this handbook to analyze such networks in detail. For completeness, however, we will present a simple design procedure for each type of network in this section.

An example of a bridged-T network is shown in Fig. 2-9. The

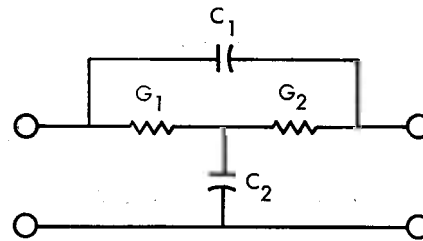

Fig. 2-9. Bridged-T RC Network

units for the elements of this network are farads for the capacitors and mhos ($G = 1/R$) for the resistors. For a transfer admittance frequency normalized to one radian/second, and of the form

$$-Y_{12} = \frac{s^2 + as + 1}{s + \alpha} \quad (7)$$

the elements will have the following values:

$$\begin{aligned} C_1 &= .0 & G_2 &= 1/(\alpha - 1/G_1) \\ G_1 &= 2.5 - \alpha & C_2 &= G_1 G_2 \end{aligned} \quad (8)$$

Such a network is not useful for producing zeros that lie close to the $j\omega$ axis, for small values of the constant α in the numerator of equation (7). A useful range of the constant α for this circuit is

$$1/2 < \alpha < 2 \quad (9)$$

It should be noted that the usual frequency and impedance normalizations must be applied to this circuit to determine the actual element values.

An example of a twin-T network is shown in Fig. 2-10. If the network elements are chosen such that

$$\begin{aligned} (10) \quad A_1 &= C_1 = G_1 = (5 - \alpha) \frac{1 + \alpha}{2 + \alpha} \\ A_2 &= C_2 = G_2 = A_1 / (A_1 - 1) \\ A_3 &= C_3 = G_3 = A_1 A_2 / (1 + \alpha) \end{aligned}$$

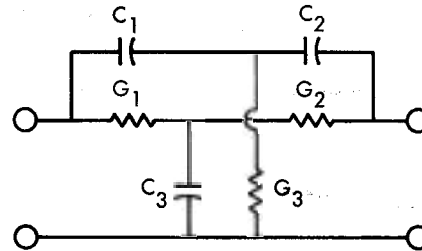

Fig. 2-10. Twin-T RC Network

the transfer admittance of this network will be

$$-Y_{12} = \frac{(s + 1)(s + as + 1)}{(s + \sigma_1)(s + \sigma_2)} \quad (11)$$

Note that in equations (10), the numerical values of the capacitors in farads and the resistors in mhos are equal. For convenience, these values have also been referred to

as A_1 , A_2 , and A_3 . The constants σ_1 and σ_2 in equation (11) can be found by the relations

$$\sigma_1 = \frac{A_1 + A_2}{A_3} \qquad \sigma_2 = \frac{1}{\sigma_1} \qquad (12)$$

This network may be used for producing zeros which are as close to the $j\omega$ axis as desired, i.e., for as small a value of the constant a as may be required. Extremely small values of a , however, may lead to oscillations in the overall active circuit. It should be noted that the numerator of the transfer admittance of this network as given in equation (11) is of third degree with a negative real zero at $-a$. The poles of the transfer admittance, however, are located with geometrical symmetry about -1 . This may be seen from the second equation of (12). It is easily shown that as the constant a approaches zero, σ_1 and σ_2 both approach unity. Thus, when a equals zero, cancellation occurs between one of the poles and the negative real zero in the numerator of the transfer admittance. Similarly, for small values of a , the numerator zero very nearly cancels one of the poles, and the transfer admittance may be assumed to have the form

$$-Y_{12} = \frac{s^2 + as + 1}{s + 1} \qquad (13)$$

without significant loss of accuracy

Network Design

Now let us consider the application of the infinite-gain single-feedback active RC circuit to the realization of three common filtering applications — the low pass, high pass, and band pass cases. For the low pass network, the frequency normalized voltage transfer function is of the form

$$\frac{E_2}{E_1} = \frac{-H}{s^2 + as + 1} \quad (14)$$

where H is a positive real constant giving the magnitude of the pass band gain. A common choice for the constant a is $\sqrt{2}$. This gives a maximally flat (sometimes called a Butterworth) frequency response characteristic. A bridged-T network of the type shown in Fig. 2-9 may be used to produce the complex conjugate poles. The element values can be found from equations (8). The bridged-T network is used as network B of Fig. 2-4. The transfer admittance for network A must have no finite zeros, but must have a single negative real pole. A network satisfying these requirements is

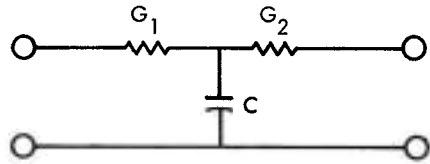

Fig. 2-11. Low Pass Network A

shown in Fig. 2-11. This network has the transfer admittance

$$-Y_{12} = \frac{G_1 G_2 / C}{s + (G_1 + G_2) / C} \quad (15)$$

Since this network must have the same pole location as network B, the factor $(G_1 + G_2)/C$ must be set equal to the constant a. The complete network, together with summary of the design procedure, and some sample element values is given in the circuit section of this handbook as Circuit No.

For the high pass network, the frequency normalized voltage transfer function will be of the form

$$\frac{E_2}{E_1} = \frac{-Hs^2}{s^2 + as + 1} \quad (16)$$

where H is a positive real constant giving the magnitude of the gain in the pass band. The same bridged-T network which was used for the low pass case may be used for network B for this case, since the poles of the transfer function will normally have similar locations. The transfer admittance for network A must now have two zeros at the origin and a single pole on the negative real axis. A network satisfying these requirements

is shown in Fig. 2-12. It has the transfer admittance

$$(17) \quad -y_{12} = \frac{s^2 C_1 C_2 / (C_1 + C_2)}{s + G / (C_1 + C_2)}$$

The element values must be chosen so

that the factor $G / (C_1 + C_2)$ equals the constant α . The complete network, a design procedure, and a set of typical element values is given in the circuit section as Circuit No. 2.

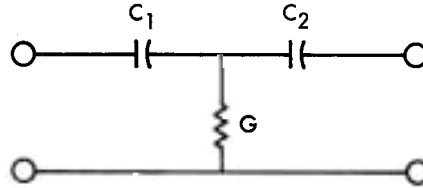

Fig. 2-12. High Pass Network A

For a band pass network, the frequency normalized voltage transfer function will be of the form

$$\frac{E_2}{E_1} = \frac{-Hs}{s^2 + as + 1} \quad (18)$$

The magnitude of the gain in the pass band for this function is H/α , where H is a positive real constant. Most band pass filter applications require that the constant α be small, i.e., that the poles be close to the $j\omega$ axis. For this case the bridged-T network is not satisfactory, and it will usually be necessary to use a twin-T network of the type shown in Fig. 2-10 as network B. If we assume that the transfer admittance of the twin-T network is of the form given in equation (13), then the transfer admittance of network A must have a single zero at the origin and a pole at -1 . A network satisfying these requirements is shown in Fig. 2-13. It has the transfer admittance

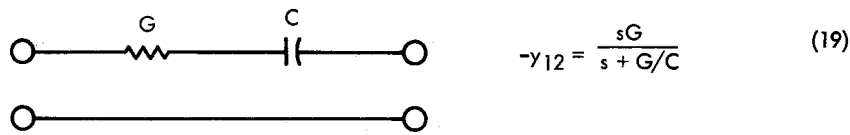

Fig. 2-13. Single Zero - Single Pole Network A

$$-y_{12} = \frac{sG}{s + G/C} \quad (19)$$

The factor G/C must be set equal to unity. The complete network, a design procedure, and a set of typical element values is given in the circuit section of this handbook as Circuit No. 3.

It should be noted that, in any realization produced by the method outlined

in this chapter, the gain constant of the complete network realization is easily adjusted by changing the impedance normalization of either of the component passive networks. This is easily seen from equation (5). For example, to raise the overall network gain, one may either lower the impedance level of network A (and thus raise the magnitude of y_{12a}) or raise the impedance level of network B (and thus lower the magnitude of y_{12b}). It should also be noted that all circuits described in this chapter produce a signal inversion in addition to the frequency dependent properties which have been noted.

Conclusions

At this point we may make some conclusions regarding some of the properties of the infinite-gain single-feedback active RC circuit configuration described in this chapter. These conclusions will assist us in determining the relative merits of this configuration as compared to the other configurations which will be described in the chapters that follow. One of the major disadvantages of this active RC circuit configuration is the large number of passive elements that it requires. For example, in the band pass network described as Circuit No. 3, we see that eight elements are needed. Another difficulty is brought about by the fact that bridged-T and twin-T networks must be used to produce the complex conjugate poles. This means that any adjustment or trimming of the pole locations will be difficult since the passive elements interact to a high degree in such networks. On the positive side of the ledger is the fact that this configuration has its pole locations determined completely by the passive networks. Thus the pole locations will remain relatively stable and independent of changes in the active element. This is a considerable advantage when it is desired to design high-Q networks, where the poles are located close to the $j\omega$ axis, since even small pole displacements may produce instability in this case. Another advantage of this configuration is that the output impedance of the network is equal to the output impedance of

the operational amplifier, which with high loop gain is very low. Thus, this circuit may be used to drive other networks, without the need for an isolating stage, and without appreciable change in the circuit characteristics due to loading. Yet another desirable feature is the capability of summing signals at the input.

CHAPTER 3

THE INFINITE-GAIN MULTIPLE-FEEDBACK CIRCUIT

In the preceding chapter an active RC network configuration described as an infinite-gain single-feedback circuit was presented. An operational amplifier was used as the active element, and a single feedback path was provided around it. In this chapter another active RC network configuration will be presented. An operational amplifier will again be used as the active element; however, more than one feedback path will be provided around it. The advantages and disadvantages of the two approaches will be compared.

The Basic Multiple Feedback Circuit

The basic circuit that will be described in this chapter consists of a number of two-terminal passive elements, interconnected so as to form feedback paths around an operational amplifier. The operational amplifier is used in an inverting configuration, with its non-inverting input terminal (terminal 2) grounded. The general circuit configuration is shown in Fig. 3-1. We shall call this circuit an infinite-gain multiple-feedback circuit. In applying this circuit to the realization of transfer functions, it is practical to restrict each of the passive two-terminal elements to a single resistor or a single capacitor. In addition, if we limit ourselves to the realization of a voltage transfer function with a single pair of complex conjugate poles, and with zeros located only at the origin of the complex frequency plane or at infinity, then a maximum of five

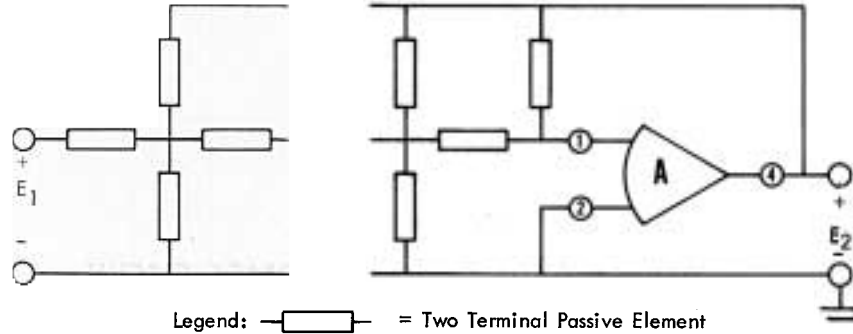
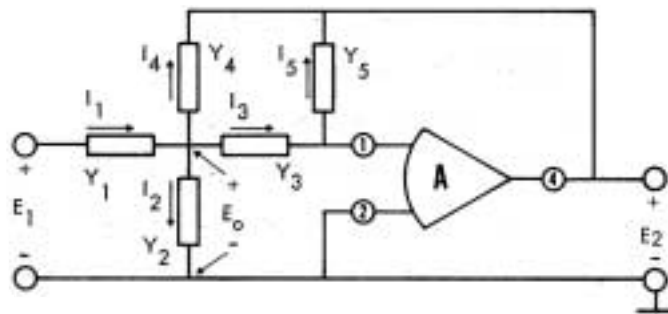

Fig. 3-1. Multiple-Feedback (MFB) Operational Amplifier Circuit

elements is necessary. The low pass, high pass, and band pass cases are included in this class of transfer functions. The extension of the method to other cases will be clear from the discussion that follows.

The Voltage Transfer Function

The basic circuit that may be used to realize voltage transfer functions with a single pair of complex conjugate poles and with zeros restricted to the origin or infinity is shown in Fig. 3-2. Each of the elements Y_i shown in this figure represents a



3-2. Basic Multiple-Feedback Circuit

single resistor or a single capacitor. Reference currents I_i and an interior voltage E_o have been defined in the figure to aid in the analysis. From the figure we may write

$$E_1 = \frac{1}{Y_1} I_1 + E_o \quad (1)$$

It is also obvious that

$$I_1 = I_2 + I_3 + I_4 \quad (2)$$

The virtual ground imposed by the operational amplifier requires that the voltage across both Y_2 and Y_3 equal E_o . Similarly, the voltage across Y_4 is the difference between E_o and E_2 . Thus we may write expressions for the branch currents as

$$\begin{aligned} I_2 &= Y_2 E_o \\ I_3 &= Y_3 E_o \\ I_4 &= Y_4 (E_o - E_2) \end{aligned} \quad (3)$$

The virtual ground also requires that $I_3 = I_5$, thus we may write

$$I_3 = Y_3 E_o = -Y_5 E_2 = I_5 \quad (4)$$

If we substitute the relations of equations (2), (3), and (4) into equation (1), we obtain

$$\frac{E_2}{E_1} = \frac{-Y_1 Y_3}{Y_5 (Y_1 + Y_2 + Y_3 + Y_4) + Y_3 Y_4} \quad (5)$$

This is the open-circuit voltage transfer function for the infinite-gain multiple-feedback circuit shown in Fig. 3-2. The elements Y_i of this network may readily be chosen so as to obtain low pass, high pass, and band pass voltage transfer functions. This will be shown in the next section

Network Design

Let us first consider the use of the infinite-gain multiple-feedback configuration to realize a low pass network. It is desired to obtain a frequency normalized voltage transfer function of the form

$$\frac{E_2}{E_1} = \frac{-H}{s^2 + as + 1} \quad (6)$$

where H is a positive real constant which specifies the gain in the pass band, i.e., the d-c gain. If we compare the above equation with equation (5), we see that in order to have the numerator not be a function of "s", both of the elements Y_1 and Y_3 must be resistors. Similarly, in order to generate the s^2 term in the denominator, Y_5 must be a capacitor, as must either Y_2 or Y_4 . Y_4 , however, must be a resistor; otherwise, it will not be possible to realize the constant term in the denominator (this must come from the product Y_3Y_4). Thus, we must make the following choices for the elements of the circuit shown in Fig. 3-2:

$$\begin{aligned} Y_1 &= G_1 & Y_3 &= G_3 \\ Y_2 &= sC_2 & Y_4 &= G_4 \\ Y_5 &= sC_5 \end{aligned} \quad (7)$$

The circuit with these elements is shown in Fig. 3-3. The voltage transfer function for

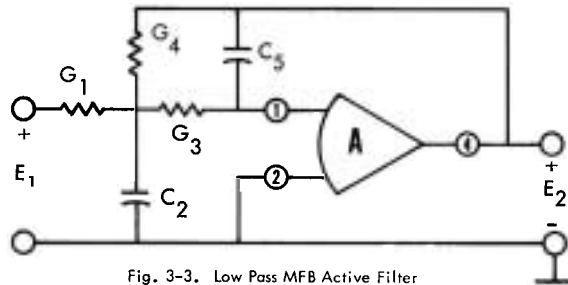

Fig. 3-3. Low Pass MFB Active Filter

this circuit is

$$\frac{E_2}{E_1} = \frac{-G_1 G_3}{s^2 C_2 C_5 + s C_5 (G_1 + G_3 + G_4) + G_3 G_4} \quad (8)$$

It should be noted that this circuit produces a signal inversion, as will be true for all the circuits realized by this technique. The specific solutions for the element values

in terms of the constants a and H may be found by equating corresponding coefficients in equations (6) and (8). Such a process leads to a simultaneous set of equations which are, unfortunately, non-linear. The nature of the set of equations is such, however, that constraints may be applied to develop a set of solutions. Such a set of solutions, together with other design information, is given in the circuit section of this handbook as Circuit No. 4. It should be noted that although the solutions given have been found to give good experimental results, they are not unique; i.e., other sets of solutions also exist.

The high pass network can be considered in a manner similar to the low pass network. The frequency normalized high pass voltage transfer function will be of the form

$$\frac{E_2}{E_1} = \frac{-Hs^2}{s^2 + as + 1} \quad (9)$$

where H is a positive real constant which specifies the gain in the pass band, i.e., the high frequency gain. The network elements shown in Fig. 3-2 must be chosen as follows:

$$\begin{aligned} Y_1 &= sC_1 & Y_3 &= sC_3 \\ Y_2 &= G_2 & Y_4 &= sC_4 \\ Y_5 &= G_5 \end{aligned} \quad (10)$$

The resulting voltage transfer function may be expressed in terms of the network elements as

$$\frac{E_2}{E_1} = \frac{-s^2 C_1 C_3}{s^2 C_3 C_4 + s G_5 (C_1 + C_3 + C_4) + G_2 G_5} \quad (11)$$

The circuit configuration is shown in Fig. 3-4. The same comments that were made

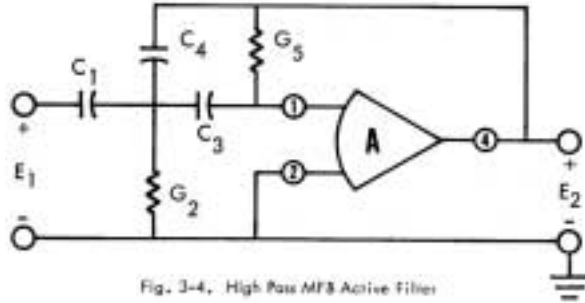

Fig. 3-4. High Pass MFB Active Filter

with respect to solving for the element values in the low pass network also apply in this case. A set of design equations and a summary of other information on this circuit is given in the circuits section of this handbook as Circuit No.5.

There are several configurations of five elements which can be used to realize a band pass network with a frequency normalized transfer function of the form

$$\frac{E_2}{E_1} = \frac{-Hs}{s^2 + as + 1} \quad (12)$$

where H is a positive real constant and H/a is the magnitude of gain in the pass band. One of the most practical configurations is the one defined by the following choice of elements:

$$\begin{aligned} Y_1 &= G_1 & Y_3 &= sC_3 \\ Y_2 &= G_2 & Y_4 &= sC_4 \\ Y_5 &= G_5 \end{aligned} \quad (13)$$

For such a choice, the voltage transfer function may be written in terms of the elements as

$$\frac{E_2}{E_1} = \frac{-sG_1C_3}{s^2C_3C_4 + sG_5(C_3 + C_4) + G_5(G_1 + G_2)} \quad (14)$$

The circuit configuration is shown in Fig. 3-5. A set of non-linear equations must be

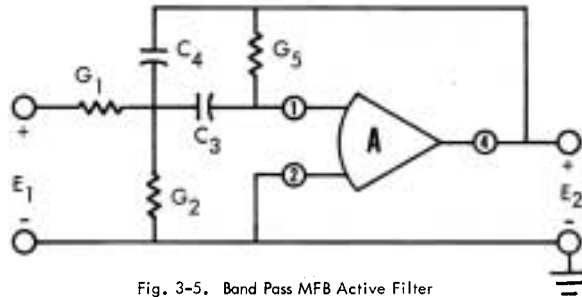

Fig. 3-5. Band Pass MFB Active Filter

solved for the element values. The solutions and the circuit design information is given in the circuits section of this handbook as Circuit No. 6.

Conclusions

In a manner similar to that of the last chapter, we may make some conclusions regarding the characteristics of the infinite-gain multiple-feedback circuit configuration. One advantage we see is that the number of elements is greatly reduced from the number required for the infinite-gain single-feedback circuits of the preceding chapter. For example, for the low pass and high pass circuits, a maximum of five elements is required, compared with seven for the single-feedback circuit. As may be seen from the design equations given in the circuits section of the handbook, there are also cases in which one of the five elements may be eliminated. In the band pass case, four or five elements are required rather than eight, a considerable saving. The same advantage of low output impedance which was pointed out for the single-feedback circuit holds true for the multiple-feedback circuit, since the output impedance of the circuit is just the closed loop output impedance of the operational amplifier. Thus this circuit may be used to drive other circuits without degradation of performance due to loading effects.

The multiple-feedback circuit, however, has some disadvantages which the

single-feedback circuit does not. For example, it is not possible to obtain high Q band pass realizations with the multiple-feedback configuration without resorting to large spreads of element values. Another disadvantage is the fact that since feedback is made to two points, there is no one single point in the circuit which can be used to sum separate signals as could be done in the single-feedback configuration. Also, if it is desired to realize transfer functions with zeros other than at the origin or infinity, the networks and the design procedure for the multiple-feedback case become considerably more complicated. Finally, this approach, in general, cannot be used to achieve as large a value of gain constant as may be obtained by the single-feedback configuration. Articles have appeared in the literature discussing the application of the infinite-gain multiple-feedback circuit configuration to the realization of more complicated transfer functions. For the reader who wishes to pursue this topic further, some references are given in Appendix A.

CHAPTER 4

THE CONTROLLED SOURCE CIRCUIT

In the preceding chapters, some general properties of active RC circuits were introduced, and two types of active RC circuit configurations were analyzed. Both of these configurations required an active element with a high value of gain. Thus, they were referred to as "infinite-gain" realizations, and an operational amplifier was used to provide the gain. In this chapter a quite different circuit configuration will be presented. It requires an active element with a relatively low value of gain, which we shall refer to as a controlled source.

In general, a controlled source is an active network element which has an output voltage or current which is a function of some single input voltage or current, but is unaffected by any of the other voltages or currents in the network. There are four types of controlled sources: the voltage-controlled voltage source, the current-controlled voltage source, the voltage-controlled current source, and the current-controlled current source. Certain physical devices have characteristics which make them act in a manner similar to some of these sources. For example, a transistor acts somewhat like a current-controlled current source. Similarly, a pentode acts very nearly like a voltage-controlled current source.

The Voltage-Controlled Voltage Source

In our discussion of the use of controlled sources in active RC circuits, we

will limit ourselves to a single type of source, an ideal voltage amplifier with infinite input impedance, zero output impedance, and an output voltage which is equal to the input voltage multiplied by some positive or negative constant. This device we shall refer to as a VCVS (voltage-controlled voltage source). A circuit model for it is shown in Fig. 4-1. From this figure we see that $E_2 = KE_1$, where the constant K is usually referred to as the "gain." It may be either positive or negative. The circuit symbol which we shall use for the VCVS is shown in Fig. 4-2.

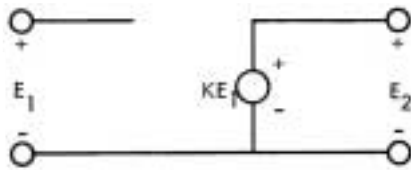

Fig. 4-1. VCVS Circuit Model

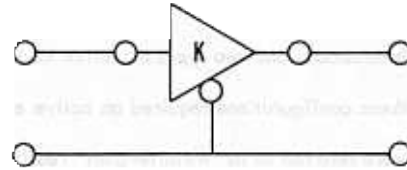

Fig. 4-2. VCVS Circuit Symbol

Now let us see how we can realize a VCVS with an operational amplifier. For the values of K that are positive and greater than unity, the circuit shown in Fig. 4-3 may be used. Note that in this circuit, the non-inverting terminal of the operational amplifier (terminal 2) is used as the input terminal. Using the virtual ground concept introduced in Chapter 1, we see that terminals 1 and 2 must be at the same potential. Since the voltage at terminal 1 is equal to $R_a I_1$, the voltage at terminal 2 must be the same; therefore, $E_1 = R_a I_1$. No current flows into the operational amplifier terminals; therefore, the currents I_1 and I_2 are equal. Thus $E_2 = (R_a + R_b) I_1$. Combining these relations we obtain

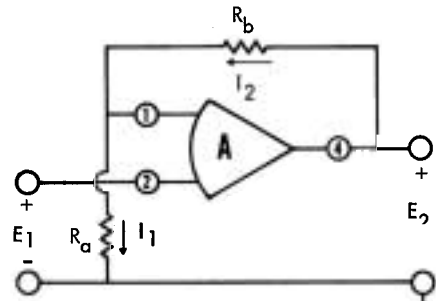

Fig. 4-3. Non-Inverting Operational Amplifier VCVS

$$\frac{E_2}{E_1} = \frac{R_a + R_b}{R_a} \quad (1)$$

Since the input impedance at terminal 2 (as well as that at terminal 1) of the operational amplifier is very large, the circuit shown in Fig. 4-3 may be considered as an ideal VCVS with a value of K equal to $(R_a + R_b)/R_a$. It should be noted that the idealness of this VCVS realization is relatively independent of the impedance levels which are chosen for R_a and R_b . In practice, values of R_a in the range of 100 k ohms will usually prove satisfactory.

Network Design

The controlled source described in the last section may be used, in connection with passive RC networks, to obtain various network functions. The first such function that we shall consider is the transfer function for the low pass network. The frequency normalized voltage transfer function is

$$\frac{E_2}{E_1} = \frac{H}{s^2 + as + 1} \quad (2)$$

where H is a positive real constant giving the value of the gain in the pass band. A network configuration which will produce this function is shown in Fig. 4-4. In terms

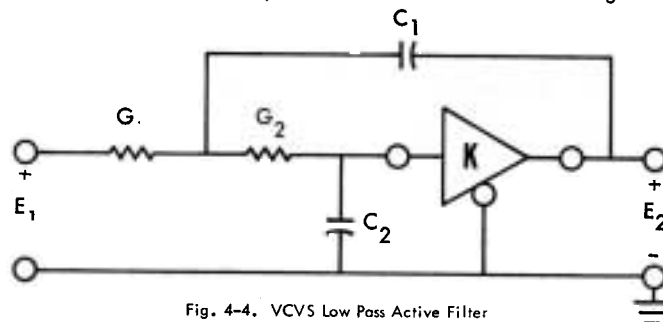

Fig. 4-4. VCVS Low Pass Active Filter

of the elements shown in this figure, we may write the voltage transfer function as

$$\frac{E_2}{E_1} = \frac{KG_1G_2}{s^2C_1C_2 + s(C_2G_1 + C_2G_2 + C_1G_2 - KC_1G_2) + G_1G_2} \quad (3)$$

From the preceding equations we see that no signal inversion is introduced by this network configuration

The transfer function given in equation (3) points out some interesting properties of this circuit realization. First of all, the low frequency gain, the gain in the pass band, may be found by evaluating equation (3) in the limit as " s " approaches

It is readily seen that this gain is simply equal to K . In other words, the gain specified for the circuit directly determines the gain of the VCVS. Second, if it is desired to change the value of the cutoff frequency for this circuit, this may be done by changing the values either of the resistors or the capacitors. Such changes will not affect the gain in the pass band. If, in addition, the changes are made in such a way that the ratio of the two elements changed remains the same, i.e. if the same percentage change is made to each of them, then the relative shape of the magnitude and phase characteristics of the network will remain unchanged. Thus this filter has the property that its cutoff frequency can be readily shifted

The values of the network elements must be found by simultaneously equating the coefficients of equations (2) and (3). The resulting set of equations is non-linear, but solutions for the element values in terms of the constants a and H are easily found. A set of solutions, together with other design information for the circuit is given in the circuits section of the handbook as Circuit No.

The low pass circuit described above is sometimes modified to the configuration shown in Fig. 4-5. If this figure and Fig. 4-4 are compared, it is easily seen that the right terminal of the capacitor C_1 has been moved from the output of the operational amplifier (which is also the output of the controlled source) to the junction of the two resistors R_a and R_b , whose values determine the gain of the controlled source. If the magnitude of the impedance of the capacitor C_1 is much larger than the values of the resistors R_a and R_b , so that the capacitor does not load the resistor network, then the voltage transfer function for the circuit shown in Fig. 4-5 is

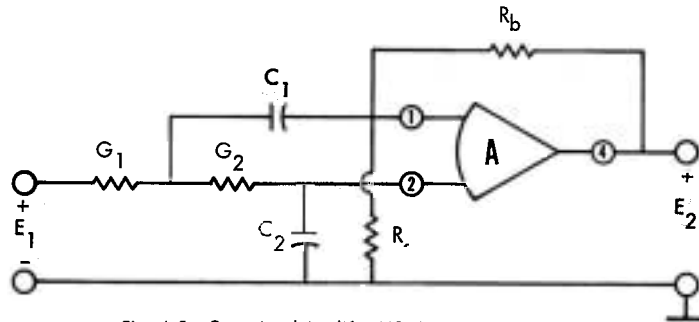

Fig. 4-5. Operational Amplifier VCVS Low Pass Active Filter

$$\frac{E_2}{E_1} = \frac{KG_1G_2}{s^2C_1C_2 + s(C_2G_1 + C_2G_2) + G_1G_2} \quad (4)$$

The above equation illustrates one advantage of this configuration; i.e. none of the coefficients in the denominator are a function of K , the gain of the controlled source. Thus K may be varied, changing the gain of the network, without changing the frequency characteristics of the network. Such a change of gain may, of course, be accomplished by varying either R_a or R_b in Fig. 4-5. It should be noted that this circuit also has a disadvantage. Since there is no subtraction of terms in the coefficient of the first degree term in the denominator of equation (4), it is not possible to realize transfer functions of the type given in equation (2) in which the constant a has very small values.

The frequency normalized voltage transfer function for a high pass network is

$$\frac{E_2}{E_1} = \frac{Hs^2}{s^2 + as + 1} \quad (5)$$

A realization for such a transfer function using a VCVS as the active element is shown in Fig. 4-6. The voltage transfer function is

$$\frac{E_2}{E_1} = \frac{Ks^2C_1C_2}{s^2C_1C_2 + s(C_1G_2 + C_2G_2 + C_2G_1 - KC_2G_1) + G_1G_2} \quad (6)$$

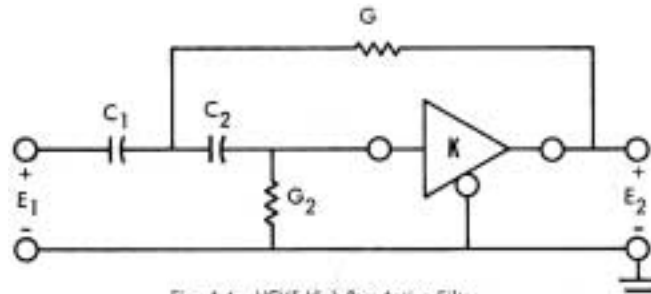

Fig. 4-6. VCVS High Pass Active Filter

The same comments that were made with respect to the low pass network also apply here; namely, H is positive, and the pass band gain (in this case the high frequency gain) is equal to the gain K of the VCVS and is not a function of the passive elements of the network. Similarly, the cutoff frequency can be changed by changing the values of the resistors or the capacitors, and, if equal percentage changes of the elements are made, the relative shape of the frequency characteristics of the network will remain unchanged. A set of formulas for determining the values of the network elements, together with other design information, is given in the circuits section of the handbook as Circuit No. 8.

In a manner similar to that which was done for the low pass network, the high pass configuration shown in Fig. 4-6 may be modified to the configuration shown in 4-7, by moving the right terminal of the resistor labeled G_1 from the output of the con-

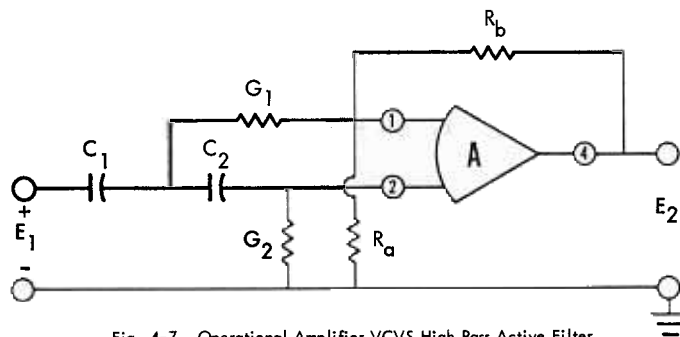

Fig. 4-7. Operational Amplifier VCVS High Pass Active Filter

trolled source to the junction of the two resistors R_a and R_b . If the magnitude of the

resistance of the element G_1 is much larger than the values of the resistors R_a and R_b , so that the gain-determining resistor network is not loaded, then the voltage transfer function for the circuit shown in Fig. 4-7 is

$$\frac{E_2}{E_1} = \frac{Ks^2C_1C_2}{s^2C_1C_2 + s(C_1G_2 + C_2G_2) + G_1G_2} \quad (7)$$

Since none of the denominator coefficients in equation (7) are functions of K , the gain of the controlled source, this gain may be varied, changing the gain of the network without changing the frequency characteristics of the network. As in the low pass case, is not possible to realize a voltage transfer function of the type given in equation (5) which the constant a has very small values

frequency normalized voltage transfer function for a band pass network is

$$\frac{E_2}{E_1} = \frac{Hs}{s^2 + as + 1} \quad (8)$$

where H is a positive real constant and H/a is the gain in the pass band. There several network configurations using a VCVS as the active element which may be used to realize such a transfer function. One such configuration which has been found to give good experimental results is shown in Fig. 4-8. The voltage transfer function in

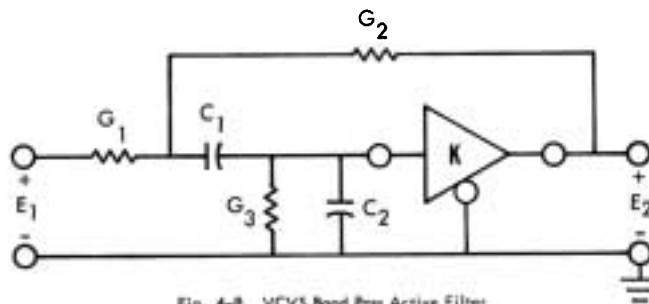

Fig. 4-8. VCVS Band Pass Active Filter

terms of the elements is (9)

$$\frac{E_2}{E_1} = \frac{sKC_1G_1}{s^2C_1C_2 + s(C_1G_3 + C_2G_1 + C_2G_2 + C_1G_1 + C_1G_2 - KC_1G_2) + G_3(G_1 + G_2)}$$

It should be noted that in the denominator, K , the gain of the controlled source, appears only in the coefficient of the first degree term. Thus, in high Q realizations, we may adjust the real part of the pole locations by varying K without appreciably affecting the resonant frequency. Since this adjustment may be made by varying the value of either of the resistors associated with the operational amplifier realization for the VCVS (see Fig. 4-3), this is a very convenient means of adjusting the Q of the network. From equation (9) we see that such adjustments will also change the overall gain constant H , but this is usually a minor effect. The design information for this circuit is given in the circuits section of the handbook as Circuit No. 9

Other Realizations with Voltage-Controlled Voltage Sources

Up to this point, in this chapter we have described active RC circuit configurations which have required a non-inverting VCVS. There are also many network configurations which require the use of an inverting VCVS, e., one in which K , the gain constant, is negative. Such a source may be produced by an operational amplifier and

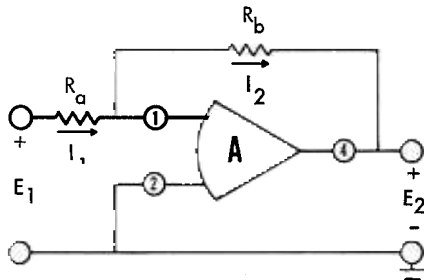

Fig. 4-9. Inverting Operational Amplifier VCVS*

the circuit shown in Fig. 4-9. Note that in this circuit the non-inverting terminal (terminal 2) of the operational amplifier is grounded. If we apply the virtual ground concept to this circuit we see that $E_1 = I_1 R_a$. Similarly,

$I_2 = I_1$, and therefore $E_2 = -I_1 R_b$. Thus we may write

$$\frac{E_2}{E_1} = \frac{-R_b}{R_a} \quad (10)$$

For large values of R_a , this circuit may be considered as an ideal VCVS with a value

of K equal to $-R_b/R_a$. Since the resistor R_a must be chosen large, this places a limit on the maximum gain value that K may have, as well as on the frequency range over which the circuit will effectively model the ideal VCVS. Actual values of R_a to be used will necessarily depend on the impedance level of the rest of the circuit, but values of the general order of 100 k ohms to 1 Megohm are not uncommon

An example of the use of an inverting VCVS to realize a low pass transfer function as given in equation (2) is shown in Fig. 4-10. The voltage transfer function

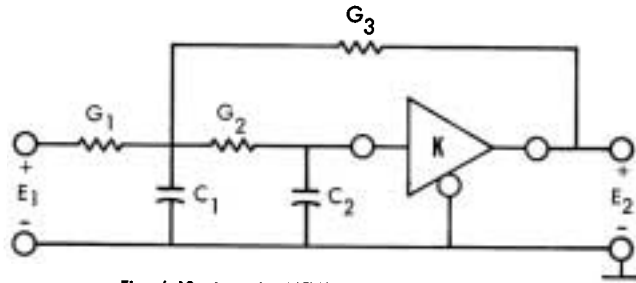

Fig. 4-10. Inverting VCVS Low Pass Active Filter

for this network is

(11)

$$\frac{E_2}{E_1} = \frac{-|K| G_1 G_2}{s^2 C_1 C_2 + s [C_2(G_1 + G_2 + G_3) + C_1 G_2] + G_2(G_1 + G_3 + |K| G_3)}$$

To avoid misinterpretation, the negative sign associated with the constant K has been written into the equation, and the gain is expressed as a magnitude. In a similar manner the inverting VCVS may be used to realize a high pass network function of the type given in equation (5). The circuit is shown in Fig. 4-11. The voltage transfer function

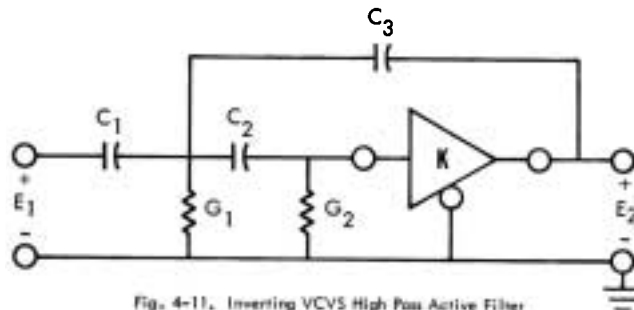

Fig. 4-11. Inverting VCVS High Pass Active Filter

for this circuit is (12)

$$\frac{E_2}{E_1} = \frac{-|K|s^2C_1C_2}{s^2C_2(C_1 + C_3 + |K|C_3) + s[C_2G_1 + G_2(C_1 + C_2 + C_3)] + G_1G_2}$$

The gain K has been shown as a magnitude in the same manner that was done in equation (11). It is also theoretically possible to use the inverting VCVS to realize a band pass transfer function. However, the value of the gain that is required for the source for even a moderately high value of Q is usually excessively high. Thus, such an application is of only limited value.

Conclusions

The active RC circuits using controlled sources which have been described in this chapter have several advantages and disadvantages when compared to the circuits of the preceding chapters. First, a new and different variable appears in the transfer function equations, namely K , the gain of the controlled source. In the infinite-gain realizations given in Chapters 2 and 3, the network functions were almost completely unaffected by changes in the gain. In the realizations of this chapter, however, not only is there a strong dependence on the gain of the source, but this effect may actually be used to vary the properties of the network. Thus, the presence of the gain as a variable is both an advantage and a disadvantage, and the potential user of these circuits must be aware of both.

The high and low pass networks that use the controlled source present another new and useful characteristic; i.e., the pass band gain is independent of the element values. This has considerable application for the case where the cutoff frequencies are to be varied without changing the gain. It should also be noted that the circuits presented in this chapter have the same low output impedance that the infinite-gain realizations had. Thus, they may be used to drive other circuits without using isolating amplifier stages between them and the circuits that follow.

CHAPTER 5

THE NIC IN ACTIVE RC CIRCUITS

In the first chapter of this handbook, the concept of an active device called an NIC (negative-immittance converter) was introduced. It was pointed out that an NIC could be used in connection with resistors and capacitors to realize a wide range of network functions. In this chapter we shall explore some of the properties of this device and see in detail how it can be used in active RC circuits.

The NIC (Negative-Immittance Converter)

Basically, the NIC is a two-port device which has the property that the impedance seen at either of its ports is the negative of the impedance connected to the other port. This "negative" action can come about in either of two ways. As a first way, the NIC can invert the direction of current flow with respect to that which would normally occur in a passive network, without disturbing the relative polarity of the input and output voltages. For example, consider a two-port network with a load impedance Z as shown in Fig. 5-1. If a current I_Z flows out of port 2 as shown,

then we would expect that a current I_1 would flow into port 1 (assuming that the

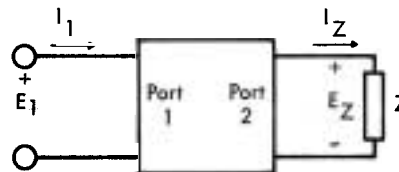

Fig. 5-1. Two-Port Network With Load

output voltage E_Z and the input voltage E_1 have the same polarity). If the two-port device somehow inverts one of these currents, then we have the situation wherein the

application of voltage E_1 to port 1 causes a current to flow in a direction opposite to that shown for I_1 ; i.e., it opposes the applied voltage. In other words, the input impedance is negative. More formally, such a device can be defined in terms of the two-port variables

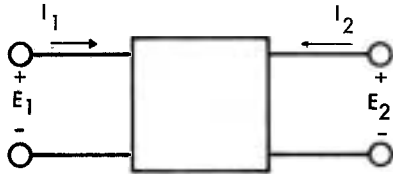

Fig. 5-2. The Port Variables for a Two-Port Network

shown in Fig. 5-2, and the equations

$$\begin{aligned} E_1 &= E_2 \\ I_1 &= KI_2 \end{aligned} \quad (1)$$

These equations may be said to define an ideal current-inversion negative-immittance converter or INIC for short. The constant K is usually referred to as the "gain" of the INIC. In the next section we shall show that such a device can be easily realized by a single differential-input operational amplifier.

Let us investigate some properties of the INIC. First of all, consider the case where an impedance Z_2 is connected across the terminals of port 2 as shown in Fig. 5-3. The variables of port 2 are then constrained by the relation $E_2 = -Z_2 I_2$. Substituting this relation into equations (1) we see that

$$Z_{IN} = \frac{E_1}{I_1} = -\frac{Z_2}{K} \quad (2)$$

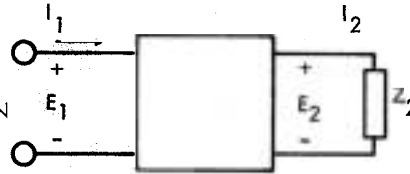

Fig. 5-3. INIC Input Circuit

Thus the input impedance at port 1 is

$1/K$ times the negative of the impedance connected across port 2. Thus we see that the magnitude of this negative impedance may be easily varied by changing the gain K of the INIC. Similarly, if an impedance Z_1 is connected across port 1 of the INIC

as shown in Fig. 5-4, then the impedance Z_{OUT} seen at port 2 may be shown to be

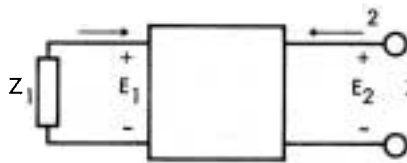

Fig. 5-4. INIC Output Circuit

$$Z_{OUT} = \frac{E_2}{I_2} = -KZ_1 \quad (3)$$

It should be noted that again a negative impedance is produced, but that in this case

the gain constant K has the opposite effect to the one it had in equation (2). For the case where $K = 1$, the INIC will theoretically give the same results in either direction. Practically, however, stability considerations based on the network configuration in which the INIC is used usually do not permit interchanging ports 1 and 2 of the INIC, even for the unity gain case. More will be said about this when discussing the realization of the INIC.

A second way in which the "negative" action of an NIC can be brought about is by inverting the voltage while keeping the direction of current flow through the two-port device unchanged. In terms of the variables shown in Fig. 5-2, this type of NIC is defined by the relations

$$\begin{aligned} I_1 &= -I_2 \\ E_1 &= -KE_2 \end{aligned} \quad (4)$$

Such a device may be referred to as an ideal voltage-inversion negative-immittance converter or VNIC for short. The constant K is called the "gain" of the VNIC.

Space does not permit developing some of the other properties of the NIC such as power relationships, impedance transformations, etc. The reader who is interested in learning more about this device should consult the references listed in Appendix A.

A Realization for the INIC

An INIC (ideal-current-inversion negative immittance converter) may be realized by using a differential-input operational amplifier as the active element. The circuit is shown in Fig. 5-5. We may analyze this circuit by means of the virtual ground concept introduced in Chapter 4. This concept tells us that the voltage between terminals 1 and 2 of the operational amplifier is zero; thus we see that the voltages at the

two ports of the overall network shown in Fig. 5-5 are equal. Similarly, we know that no current flows into either of the amplifier terminals 1 and 2. Since the voltage across the two resistors R_1 and R_2 must be the same, we see that $I_1 R_1 = I_2 R_2$; in other words, the ratio of the currents at the two ports is determined by the ratio of the resistors. We may write the above relationships as

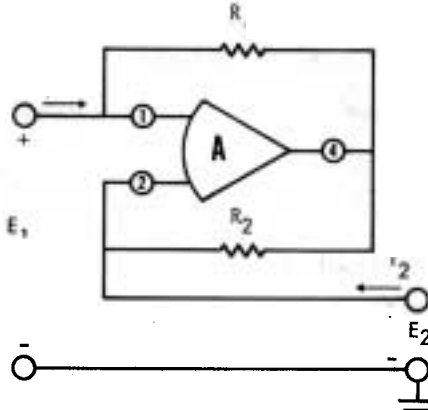

Fig. 5-5. Operational Amplifier Realization of the INIC

$$\begin{aligned} E_1 &= E_2 \\ I_1 &= \frac{R_2}{R_1} I_2 \end{aligned} \quad (5)$$

These are the same relations given in equations (1), with $K = R_2/R_1$. Thus we see that the circuit shown in Fig. 5-5 has the properties of an INIC, and that the gain constant K may be easily adjusted by changing the values of either of the resistors R_1 or R_2 .

Stability of the INIC

In the discussion given above, it was assumed that the voltage between terminals 1 and 2 of the operational amplifier was zero. This assumption greatly simplified the analysis of the circuit. Actually, there will always be a small voltage present between these terminals. In the INIC circuit this small voltage becomes a significant factor in determining whether the circuit will be stable. To see this, consider the case where a resistor R_a is connected across port 1 of the INIC shown in Fig. 5-5, and another resistor R_b is connected across port 2. The circuit may be redrawn using the model for the operational amplifier shown in Fig. 1-1 of Chapter 1. The result is shown in

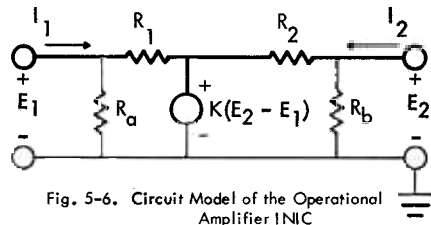

Fig. 5-6. Circuit Model of the Operational Amplifier INIC

Fig. 5-6. The constant K shown in this figure represents the gain of the operational amplifier (not the gain of the INIC). In order for this circuit to be stable, the voltage $E_2 - E_1$, even

though it is small, must never be positive. If it should go positive, the feedback provided by the resistor networks will drive the operational amplifier into saturation.

Therefore, the condition for stability is

$$E_1 \geq E_2 \quad (6)$$

The voltages E_1 and E_2 , however, if the currents I_1 and I_2 are zero, may be expressed in terms of the four resistors shown in Fig. 5-6. Thus the inequality given in equation (6) may also be expressed as

$$\frac{R_a}{R_1} \geq \frac{R_b}{R_2} \quad (7)$$

This may be reduced to

$$R_a R_2 \geq R_b R_1 \quad (8)$$

For the case where R_1 and R_2 are equal, corresponding with an INIC gain of unity, we see that

$$R_a \geq R_b$$

is a necessary condition for stable operation of the INIC. To indicate this, it is customary to refer to port 1 as the open-circuit-stable (OCS) port of this INIC realization, and port 2 as the short-circuit stable (SCS) port. Similar restrictions may be developed for the situation where the INIC is imbedded in networks containing capacitors as well

as resistors, to ensure that the operational amplifier is not driven into saturation.

The Basic INIC Circuit

There are several methods that have been proposed whereby a voltage transfer function may be realized by passive networks and an INIC. We shall discuss only one of these here, some others may be found in the references listed in Appendix A. The basic circuit configuration consists of two passive RC networks labeled A and B, and an INIC, and is shown in Fig. 5-7. First let us consider the cascade connection of the B

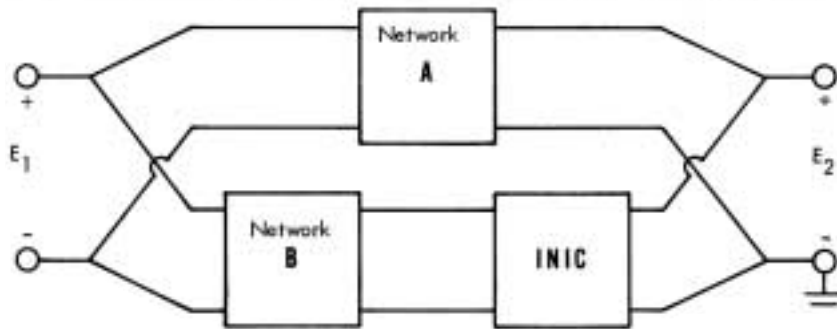

Fig. 5-7. Basic Voltage Transfer Circuit Using the INIC

network and the INIC. If we describe the properties of the B network by its y parameters, then the effect of the INIC is to invert the current at the output port of network B and also multiply it by a constant. The y parameters of the cascaded connection of the B network and the INIC may thus be shown to be

$$\begin{aligned} Y_{11} &= Y_{11b} & Y_{12} &= Y_{12b} \\ Y_{21} &= -KY_{12b} & Y_{22} &= -KY_{22b} \end{aligned} \quad (10)$$

where Y_{11b} , Y_{12b} , and Y_{22b} are the y parameters of the B network by itself, and K is the gain of the INIC. Note that for the cascade connection, Y_{12} is not equal to Y_{21} , as would be the case for a passive network. When the A network is connected in parallel, its y parameters add to those given in equations (10). Thus, the y parameters for

the overall network are

$$\begin{aligned} y_{11} &= y_{11a} + y_{11b} & y_{12} &= y_{12a} + y_{12b} \\ y_{21} &= y_{12a} - Ky_{12b} & y_{22} &= y_{22a} - Ky_{22b} \end{aligned} \quad (11)$$

Since the open-circuit voltage transfer function for an arbitrary network is simply the ratio $-y_{21}/y_{22}$, we may write the voltage transfer function of the basic circuit as

$$\frac{E_2}{E_1} = \frac{-y_{12a} + Ky_{12b}}{y_{22a} - Ky_{22b}} \quad (12)$$

In the references, some specific rules are developed for determining the parameters of the component passive networks A and B in such a way that they can be realized by passive RC networks for a given desired voltage transfer function. We shall not develop these rules here. In the next section, however, we shall show the results of applying such developments to obtain the same three types of transfer functions that we realized in earlier chapters.

Network Design

The basic circuit configuration described in the preceding section may be used to obtain various networks. The first network that we shall consider here is the low pass network having a frequency normalized voltage transfer function of the form

$$\frac{E_2}{E_1} = \frac{H}{s^2 + as + 1} \quad (13)$$

A network configuration which realizes this voltage transfer function is shown in Fig. 5-8. The elements C_2 and G_3 form the A network of Fig. 5-7. For this network we have the following y_{12} and y_{22} parameters:

$$\begin{aligned} y_{12a} &= -G_3 \\ y_{22a} &= sC_2 + G_3 \end{aligned} \quad (14)$$

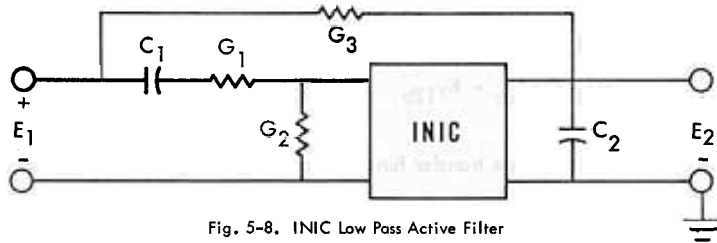

Fig. 5-8. INIC Low Pass Active Filter

The elements C_1 , G_1 , and G_2 shown in the figure form network B. This network has the y parameters

$$y_{12b} = \frac{-sC_1 G_1}{sC_1 + G_1} \quad (15)$$

$$y_{22b} = \frac{sC_1(G_1 + G_2) + G_1 G_2}{sC_1 + G_1}$$

Substituting the expressions from equations (14) and (15) into equation (12), and rearranging terms, we find that the voltage transfer for the circuit shown in Fig. 5-8 is

$$\frac{E_2}{E_1} = \frac{sC_1(G_3 - KG_1) + G_1 G_3}{s^2 C_1 C_2 + s[C_2 G_1 - KC_1 G_2 + C_1(G_3 - KG_1)] + G_1(G_3 - KG_2)} \quad (16)$$

If we constrain the elements of this network so that G_3 equals KG_1 , then equation (16) reduces to

$$\frac{E_2}{E_1} = \frac{G_1 G_3}{s^2 C_1 C_2 + s(C_2 G_1 - KC_1 G_2) + G_1(G_3 - KG_2)} \quad (17)$$

If we compare this equation with equation (13) we see that the constant H is positive; e., no signal inversion is provided by this circuit. Equations relating the values of the network elements to the constants a and H of equation (13) have been tabulated and, together with other design information on this circuit, they are presented in the circuits section of this handbook as Circuit No. 10

In a similar fashion we may use passive RC networks and an INIC to realize a

high pass network. Such a network will have a voltage transfer function of the form

$$\frac{E_2}{E_1} = \frac{s^2 H}{s^2 + as + 1} \quad (18)$$

A network configuration which realizes this function is shown in Fig. 5-9. The ele-

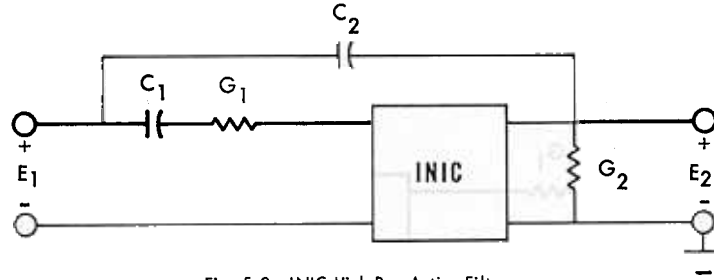

Fig. 5-9. INIC High Pass Active Filter

ments C_2 and G_2 shown in this figure constitute network A of Fig. 5-7. The y parameters for this network are

$$\begin{aligned} Y_{12a} &= -sC_2 \\ Y_{22a} &= sC_2 + G_2 \end{aligned} \quad (19)$$

The elements C_1 and G_1 constitute network B. Its y parameters are

$$Y_{22b} = -Y_{12b} = \frac{sC_1 G_1}{sC_1 + G_1} \quad (20)$$

If we substitute the expressions from equations (19) and (20) into equation (12), after rearranging terms, we find that the voltage transfer function for the overall network is

$$\frac{E_2}{E_1} = \frac{s^2 C_1 C_2 + s G_1 (C_2 - K C_1)}{s^2 C_1 C_2 + s [C_1 G_2 + G_1 (C_2 - K C_1)] + G_1 G_2} \quad (21)$$

If we constrain the elements of this network so that C_2 equals $K C_1$, then equation (21) reduces to

$$\frac{E_2}{E_1} = \frac{s^2 C_1 C_2}{s^2 C_1 C_2 + s C_1 G_2 + G_1 G_2} \quad (22)$$

We see that the constant H of equation (18) is positive. The design information for this circuit is given in the circuits section of the handbook as Circuit No. 11

As a final example of circuit design using an INIC, consider the band pass network with a frequency normalized voltage transfer function of the form

$$\frac{E_2}{E_1} = \frac{-sH}{s^2 + as + 1}$$

A circuit which realizes this function is shown in Fig. 5-10. The elements C_2 and G_2

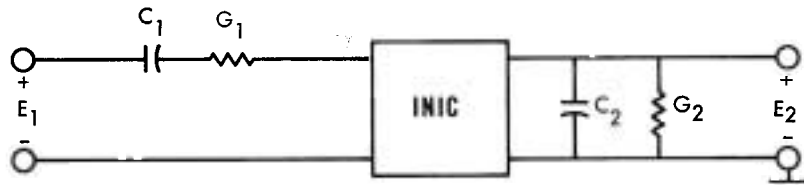

Fig. 5-10. INIC Band Pass Active Filter

comprise network A of Fig. 5-7. The y parameters are

$$y_{12a} = 0$$

$$y_{22a} = sC_2 + G_2$$

The elements C_1 and G_1 comprise network B. Its y parameters are

$$y_{22b} = -y_{12b} = \frac{sC_1 G_1}{sC_1 + G_1} \quad (25)$$

The overall voltage transfer function for the circuit may be found by inserting the relations of (24) and (25) into equation (12). After rearranging terms we obtain

$$\frac{E_2}{E_1} = \frac{-sKC_1 G_1}{s^2 C_1 C_2 + s(C_1 G_2 + C_2 G_1 - KC_1 G_1) + G_1 G_2} \quad (26)$$

Note that the constant H of equation (23) is positive for this circuit, and that the circuit provides a signal inversion.

The voltage transfer function given in equation (26) points out some of the

interesting properties that the INIC realization of the band pass network possesses. In the denominator, it should be noted that the INIC gain constant appears only in the coefficient of the first degree term. Thus, in high Q realizations, it is possible to adjust the real part of the pole positions, i.e., the Q of the circuit, without significantly changing the magnitude of the pole positions, i.e., without significantly changing the resonant frequency. At a given frequency, therefore, we can control the bandwidth of the network by changing the gain of the INIC, i.e., by varying the values of either of the resistors associated with the operational amplifier INIC realization. A second interesting feature of this network is that by choosing a non-unity INIC gain constant, it is possible to design the network so that both resistive elements have the same value, and both capacitive elements have the same value. Thus, the problem of obtaining accurately specified passive element values is considerably minimized. Finally, if both resistors have the same value and are varied the same amount, the resonant frequency of the network is changed, although the Q of the network remains invariant. The same is true if the values of the capacitors are changed in the indicated manner. Thus we have a circuit where a single resistor may be changed to vary the bandwidth, and a pair of resistors may be changed to vary the resonant frequency, and the two effects do not interact. The design equations and other information for this circuit are given in the circuits section of the handbook as Circuit No. 12.

Conclusions

In this chapter, an entirely new "breed" of circuits has been presented, namely, circuits which use an INIC as the active element. The INIC can, of course, also be used to produce single negative-valued elements which in turn can be used to compensate for dissipation, to reduce input capacitance, etc. We have used the INIC as an integral portion of circuits realizing low pass, high pass, and band pass voltage

transfer functions. The band pass circuit is an especially attractive one because of the minimum number of elements used, the fact that all elements of a given kind have the same value, and the ease with which the Q and the resonant frequency of the network may be adjusted

It should be noted that all the circuits given in this chapter share a common disadvantage; namely, their output impedance is not zero. Therefore, if such networks are cascaded, suitable isolating stages must be used to separate them. The advantage of ease of adjustment provided by some of these networks must therefore be weighed against the disadvantage of the requirement for the extra circuitry involved in isolating the filtering stages. A more detailed comparison of the advantages and disadvantages of the various realization schemes that have been presented in Chapters 2 through 5 is given in Chapter 7.

CHAPTER 6
ANOTHER ACTIVE DEVICE THE GYRATOR

In addition to the active elements which have been introduced in the preceding chapters, there is another one that deserves mention. It is called a gyrator. In this chapter we shall give a short introduction to the properties and potential uses of this element

Definition of a Gyrator

A gyrator is a non-reciprocal two-port device defined by the equations

$$\begin{aligned} I_1 &= GE_2 \\ I_2 &= -GE_1 \end{aligned} \tag{1}$$

This two-port device is usually considered to have a common ground, and, in this case, the gyrator is represented by the symbol shown in Fig. 6-1. The constant G is called the gyration conductance. The reference arrow drawn inside the circle in the figure indicates that the gyration action from terminal 1 to terminal 2 with terminal 3 common (as shown), is

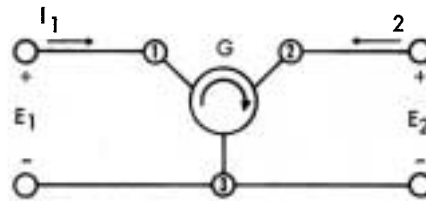

Fig. 6-1. Gyrator Symbol

the same as that which would occur from terminal 2 to terminal 3 if terminal 1 was used as the common terminal. Similarly, it is the same as that which would occur from terminal 3 to terminal 1 if terminal 2 was used as the common terminal. We shall see what

this gyration action consists of in the paragraphs that follow.

Properties of the Gyrtator

From equations (1) we see that the y parameters of a gyrtator are

$$\begin{aligned} y_{11} &= 0 & y_{12} &= G \\ y_{21} &= -G & y_{22} &= 0 \end{aligned} \tag{2}$$

If we calculate the input admittance Y_{IN} of a two-port network, defined by its y parameters, when an admittance Y_2 is connected across the terminals of port 2, as shown in Fig. 6-2 we obtain

$$Y_{IN} = y_{11} + \frac{y_{12}y_{21}}{y_{22} + Y_2} \tag{3}$$

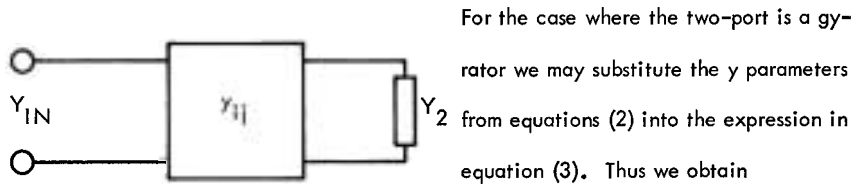

Fig. 6-2. The Input Admittance of a Terminated Two-Port Network

$$Y_{IN} = G^2/Y_2 \tag{4}$$

This is the input admittance of a gyrtator terminated in an admittance Y_2 . Equation (4) tells us that if Y_2 is a capacitor, then, at port 1 of the gyrtator we see a two-terminal behavior exactly paralleling that of an inductor. In other words, a gyrtator can be used to "gyrate" a capacitor into an inductor. Thus, with resistors, capacitors, and gyrtators, we can achieve any network realization which can be achieved with resistors, capacitors, and inductors. If we can obtain a gyrtator with a small value of G , then we can gyrate very small capacitors into very large inductors, a most useful feat!

One other property of the gyrtator may be of interest. This concerns the power

relationships at the terminals of the gyrator. For any two-port device, the total instantaneous power consumed by the device is

$$p(t) = e_1(t)i_1(t) + e_2(t)i_2(t) \quad (5)$$

Substituting relations equivalent to those given in equation (1), but in terms of functions of time, into the above equation, we see that

$$p(t) = e_1(t)i_1(t) - e_1(t)i_1(t) = 0 \quad (6)$$

Thus we see that the gyrator neither adds energy to the circuit in which it is used, nor consumes it. As such, its terminal properties are those of a lossless passive network component. We shall see, however, that its realization inevitably requires the use of active elements.

A Gyrator Realization

There are several ways of realizing a gyrator. One of the methods uses two INICs. Consider the circuit shown in Fig. 6-3. It is easily shown that this circuit has

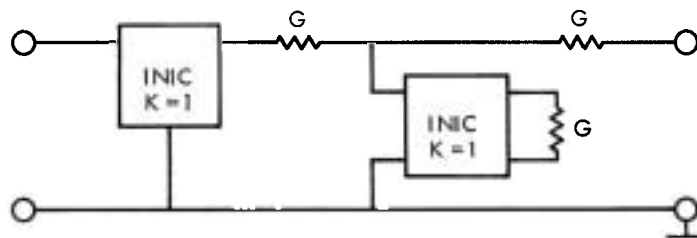

Fig. 6-3. Gyrator Realization Using Two INIC's.

the y parameters given in equation (2), and thus functions as a gyrator. The values of the resistors (in mhos) shown in the figure determine the value of the gyration conductance. References to some other methods for realizing gyrators are given in Appendix A.

Circuit Realizations

There are considerably fewer results available in the literature regarding the use of gyrators and RC circuits for the realization of transfer functions than there are for any of the other classes of networks that have been discussed in this handbook. Since the state of the art is relatively new, and since the active elements are considerably more complicated than any which have been discussed in the previous chapters, we shall not present general circuits for the realization of low pass, high pass and band pass circuits as was done in those chapters. To give an example of one form that such realizations may take, however, consider the circuit shown in Fig. 6-4.

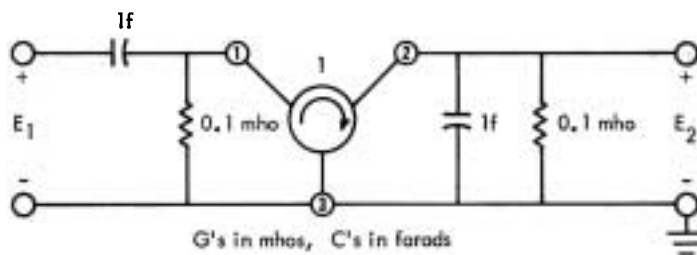

Fig. 6-4. Gyrator Band Pass Active Filter

The voltage transfer function for this circuit is

$$\frac{E_2}{E_1} = \frac{s}{s^2 + 0.2s + 1.01} \quad (7)$$

Thus, the circuit realizes a band pass voltage transfer function.

Conclusions

Due to the complicated nature of the realizations for the gyrator, this network element has not achieved a wide usage at this time. In addition to the disadvantage of complexity, realizations which use it as the active element have two other disadvantages in that their output impedance will not be zero, and they will be capable only of

the gain that a passive RLC circuit is capable of. Despite these disadvantages, the gyrator also has some potential advantages. First, its lossless nature provides a theoretical bar to circuit instability, since if no power is being supplied to the circuit, instability cannot occur. Second, since capacitors in general have a higher quality factor (lower dissipation) than inductors, gyration of a capacitor may produce a better inductor than those which are readily available. Finally, the possibility of using a gyrator for impedance multiplication implies the ability to realize very low frequency circuits without the need of relatively large-valued reactive elements.

This Page Intentionally Left Blank

CHAPTER 7

A SUMMARY

In Chapters 2 through 5 of this handbook four different active RC synthesis techniques were presented. These were the infinite-gain single-feedback technique, the infinite-gain multiple-feedback technique, a technique using controlled sources, and a technique using negative-immittance converters. The various methods were all applied to the realization of low pass, high pass, and band pass voltage transfer functions. At this point the reader may well ask, "If I want to realize a low pass function (or a high pass or a band pass one) which of the methods is best?" The answer to the question, of course, depends on how the word "best" is defined. If "best" means fewest elements, then the infinite-gain single feedback technique is certainly eliminated. If the network is to be cascaded with other networks, then the NIC approach is probably not a good one. Thus, the answer to such a question depends on the details of the application, which will vary considerably from one situation to another.

The purpose of this handbook has been to give the prospective user several different techniques for each of the filter realizations, in order to permit him flexibility in selecting the technique that more nearly meets his specific application. To provide a further guide to such a choice, some of the advantages and disadvantages of the various realization techniques are summarized in Table I. A study of this table will provide a good review of the material which has gone before.

Table
 Summary of the Advantages and Disadvantages
 of the Various Realization Techniques

Property	Realization Technique			
	Infinite-Gain Single-Feedback	Infinite-Gain Multiple-Feedback	Controlled Source	Negative-Immittance Converter
Minimal number of network elements	-	+	+	+
Ease of adjustment of characteristics	-	0	0	+
Stability of characteristics	+	+	-	-
Low output impedance	+	+	+	-
Presence of summing input	+	-	-	-
Relatively high gain available	+	-	+	+
Low spread of element values	+	-	+	+
High-Q realizations possible	+	-	+	+

+ indicates the realization is superior for the indicated property
 0 indicates the realization is average for the indicated property
 - indicates the realization is inferior for the indicated property

This concludes our introduction to the wonderful world of active RC networks, a world without inductors. It is hoped that the reader will find the techniques which have been presented in this handbook useful, and that he will be able to apply them to his own filtering problems. Needless to say, the Applications Engineering Section of Burr-Brown would welcome any questions or comments that the reader might have on the material of this booklet or on any other operational amplifier application. Feel free to call us at any time.



SECTION II

CIRCUIT COLLECTION

A search of literature in the field and Burr-Brown's seven-year collection of application notes turned up the circuits presented in this section. They have been grouped by general function and ordered within each group by increasing complexity. It is our hope that one of these will trigger the idea that develops into your circuit.

Please do not interpret any one circuit as our recommendation for your requirement. Some of them, due to their simplicity or specialized nature, may perform only over limited ranges and under controlled conditions. We would welcome the opportunity to suggest a specific circuit for you, given the details of your application.

VOLTAGE DETECTORS AND COMPARATORS

Inputs are of two types. The reference and input voltages may be connected to separate input terminals in which case E_{ref} is the actual threshold voltage and cannot exceed the common mode input voltage limit for the operational amplifier. The reference and input both may be connected through input resistors to the inverting input allowing E_{ref} to be any convenient voltage opposite in polarity to the signal voltage. Threshold voltage is set by scaling the input resistors.

Outputs may be saturation limited or may be clamped to the desired value.

In all cases, the input must swing past the threshold voltage by an amount equal to the output voltage divided by the open loop gain of the operational amplifier.

Saturation-Saturation - simple, but relatively slow response

$E_o = + \text{saturation (+10v)}, E_i < E_t$

$E_o = - \text{saturation (-10v)}, E_i > E_t$

$E_t = E_{\text{threshold}} = E_{\text{ref}}$

E_i and E_{ref} may be reversed to change polarity of output

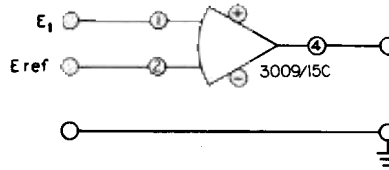

$E_o = + \text{saturation}, E_i < 1.5v$

$E_o = - \text{saturation}, E_i > 1.5v$

$E_t = - E_{ref} \frac{R_1}{R_2} = + 1.5v$

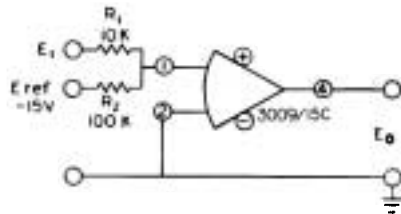

Single-Swing - simple output clamping.

$E_o = + \text{saturation}, E_i < 1.5v$

$E_o = 0, E_i > 1.5v$

Reversing diode gives 0, - saturation output

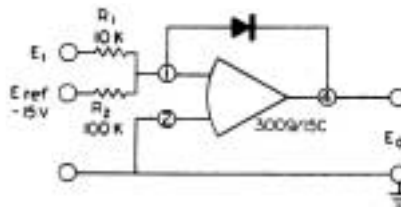

Hysteresis - output stability or decrease in sensitivity.

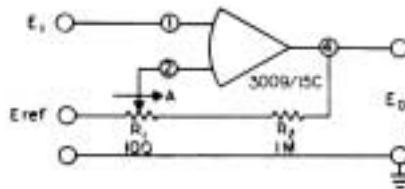

$$E_o = + \text{saturation}, E_i < E_{ref} - A$$

$$E_o = - \text{saturation}, E_i > E_{ref} + A$$

Potentiometer or fixed resistors may be used.

Half Swing - single output clamping.

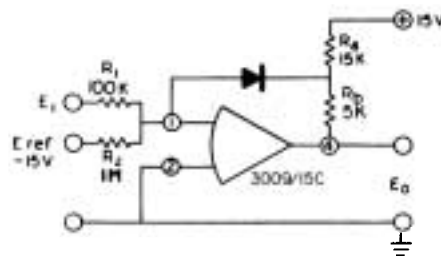

$$E_o = + \text{saturation}, E_i < 1.5$$

$$E_o = -5, E_i > 1.5$$

$$\text{Clamped output} = \frac{-E_b R_b}{R_a} = -5 \text{ volts}$$

Reversing diode and E polarity give +5, - saturation swing

Voltage Comparator - fully clamped.

$$E_o = -10, E_i > 1.5$$

$$E_o = 3, E_i < 1.5$$

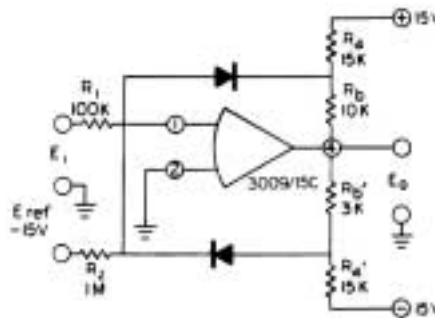

BUFFERS AND ISOLATION AMPLIFIERS

The standard inverting and non-inverting amplifier circuits provide impedance isolation due to their inherently low equivalent output impedance. The following circuits are designed principally for isolation and not for providing gain.

Voltage Follower - precision voltage source isolation, maximum common mode voltages must be limited to specified values.

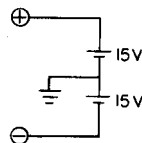
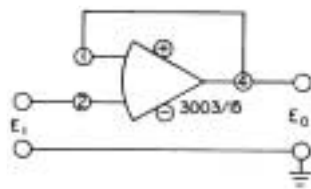

$E_o = E_1$

Model	DC Gain	Z _{in} @ 1 volt
3003/15	0.99999	> 50 Meg.Ω
1552/15	0.9999	> 10 ¹¹ ohms

Inverting Buffer - adjustable gain.

$E_o = -E_1$
 $Z_{in} = 10K$
 $Z_{out} = 1\Omega$

Potentiometer in feedback allows gain trimming to compensate for tolerance in resistor values (30Mc with 1560/25 and 1 Kohm external resistors).

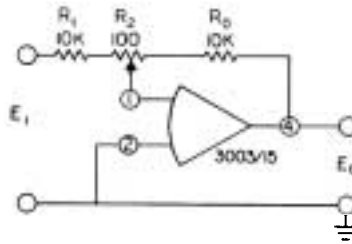

Balanced Output - for driving balanced loads or push-pull stages when ground reference is critical.

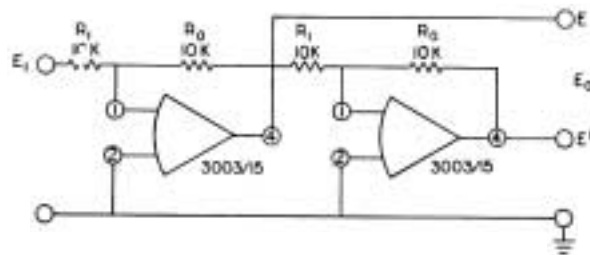

$E' = E_1$
 $E = -E_1$
 $E_o = E - E' = -2E_1$

By using E' terminal at the reference, a p-p swing of 4E₁ is obtainable at E, i.e. a usable swing of 40 volts P-P with a ±15 volt power supply.

Differential Output - similar to above but provided in a single module.

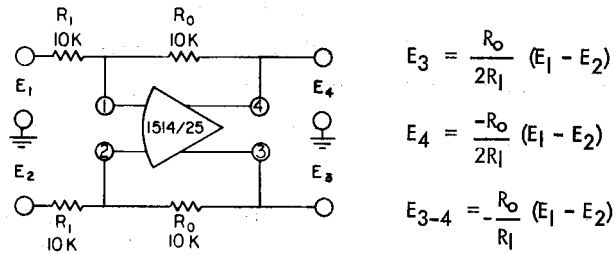

High Input Impedance - DC - Z_{in} falls with frequency giving equivalent shunt input capacitance.

Model Z_{in}
 $3003/15 > 1000 \text{ Meg } \Omega, 10\text{pf}$

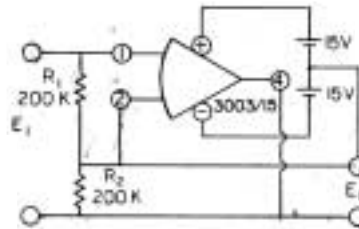

High Input Impedance - AC - same as above with input and by-pass capacitors to give improved high frequency operation.

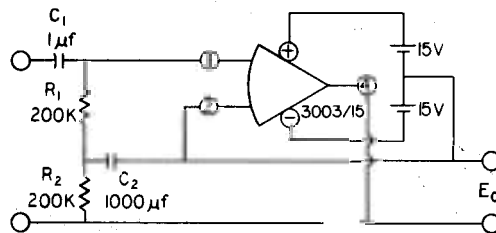

Wide Band - high speed. 30Mc response at unity gain.

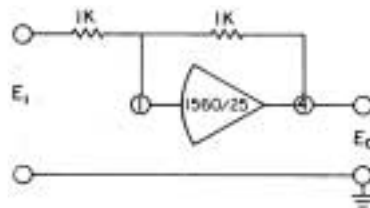

VOLTAGE AND CURRENT REFERENCES

The high input impedance and low output impedance levels which can be obtained with the precision and stability of operational amplifier circuitry make reference supplies practical. Some circuits are merely reference cells or zener diodes with isolator and multiplying circuits added. Others use the "bootstrap" technique to raise the impedance level seen by the reference to theoretical values approaching infinity.

Isolated Standard Cell - Prevent damage to standard cells induced by drawing

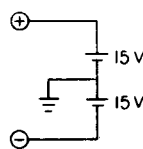
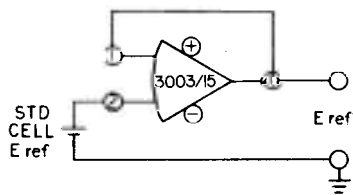

current from them with low impedance (20K/volt) measuring devices. See section on Buffers and Isolators for gain error. Offset adjustments should not be made with standard cell connected

Constant Current Generator - convenient current reference up to 20ma.

$$I = \frac{V_z}{R_2} = \frac{6}{300} = 20\text{ma}$$

$$R_1 = \frac{15 - V_z}{I_{z \text{ max}}} = \frac{9}{25\text{ma (nom)}} = 0.36\text{K}$$

$$R_L \text{ min.} = \frac{\text{Saturation Voltage}}{I} = \frac{10\text{v}}{20\text{ma}} = 500\Omega$$

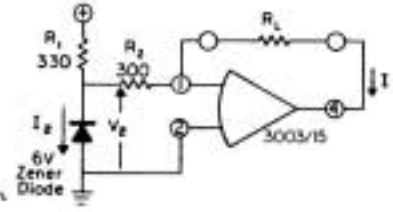

Buffer Variation - Low current drift of chopper stabilized amplifiers improves stability and cell protection.

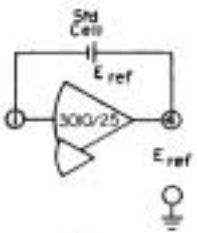

Pre-settable Voltage Source - Gives wide range of very stable reference voltages.

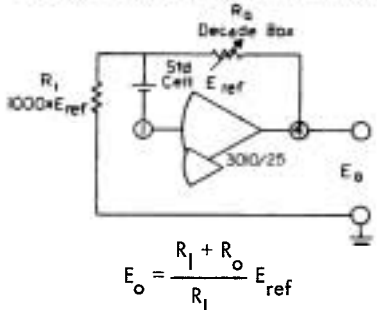

$$E_o = \frac{R_1 + R_o}{R_1} E_{ref}$$

Reference Voltage Supply – Positive and negative output with very high input impedance.

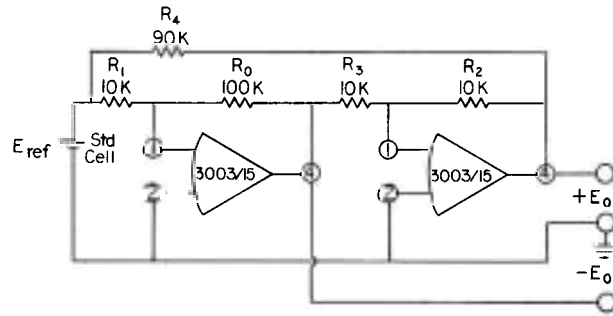

$$E_o = \frac{R_o}{R_i} E_{ref} = 10 E_{ref} \quad \text{Add } 1520/15 \text{ for } 100\text{ma output.}$$

$R_4 = R_o - R_i$ for "infinite input impedance." Should be trimmed for best results.

INTEGRATORS

Simple integrator circuits operate successfully but current offset is stored in the feedback capacitor causing output voltage error. This is corrected with low drift chopper stabilized amplifier and/or current biasing networks.

Simple Integrators -

$$E_o = \frac{-\int E_i dt}{R_i C_o} = -10 \int E_i dt$$

Close switches to reset to zero.

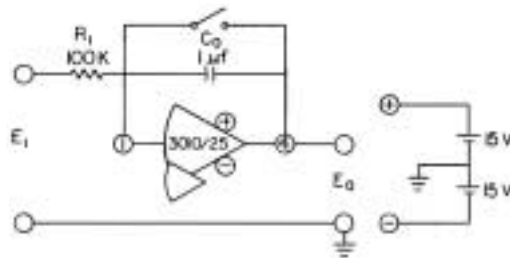

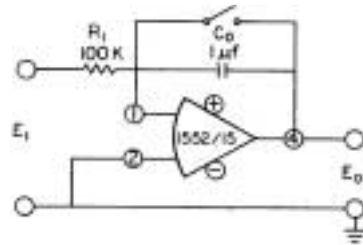

Model
1543/15
1552/15

E_0 max.
±20v
±10v

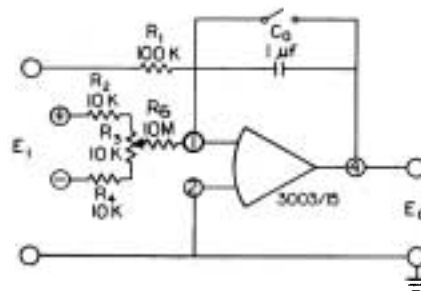

This circuit reduces current offset in operational amplifiers without "Bal" controls. With zero input and switch open, set R_3 for zero output drift.

Regeneration - may be used to increase open loop DC gain to infinity.

(1) With input open and regeneration control R_{reg} in approximate center of its range, open reset switch and adjust zero control, R_0 , until output remains at zero.

(2) Open reset switch, short input and adjust 3003/15 internal "BAL" control for zero drift.

(3) Apply an input signal of either polarity and allow integrator to run up to some voltage between ±10v DC, then open circuit signal input.

(4) If integrator output decays toward zero, increase regeneration by increasing R_{reg} . If output continues to grow, decrease regeneration.

(5) If setting of regeneration control is altered, repeat steps (1) and (2) above.

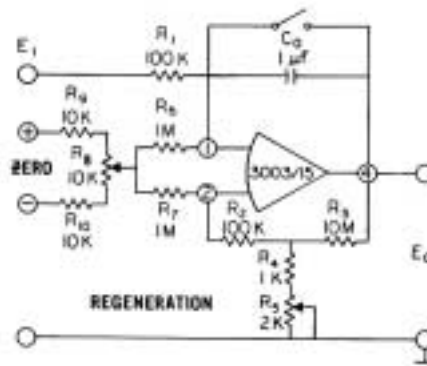

Summing Integrator - one amplifier replaces separate summer and integrator circuits.

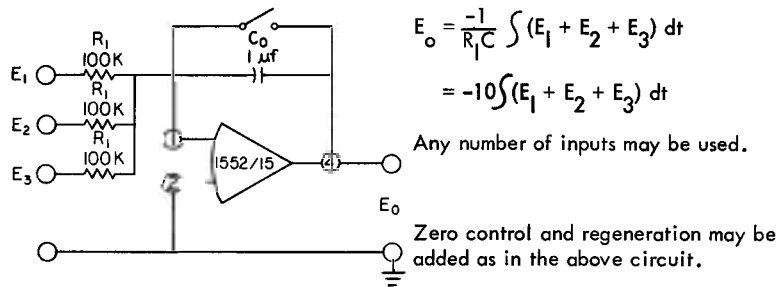

Double Integrator - integrates twice with one amplifier.

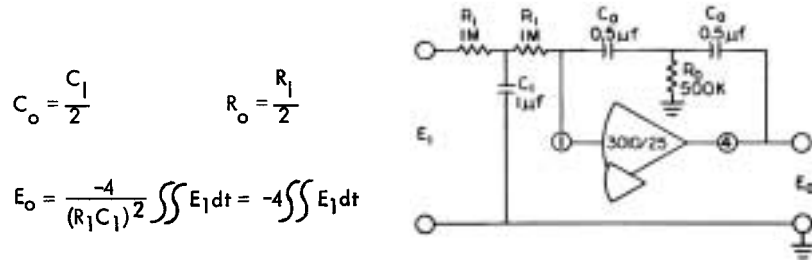

Differential Integrator - integrates difference between two signals.



AC Integrator - integrates AC component only.

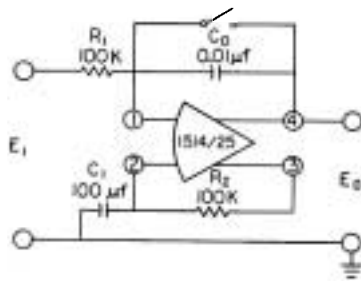

$$E_o = \frac{-1}{R_1 C_o} \int E_i dt = -1000 \int E_i dt$$

Augmenting Integrator - sums the input signal and its time integral.

$$E_o = \frac{-R_o E_i}{R_i} - \frac{1}{C_o R_i} \int E_i dt$$

$$-10 E_i - \int E_i dt$$

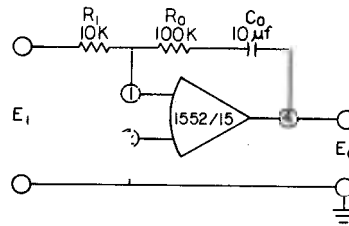

DIFFERENTIATORS

The ideal differentiator circuit is not generally usable in its simple form. It is susceptible to high frequency noise which may be greater than the derivative output. Design should include high frequency response limiting.

With "Stop" - input resistor sets high frequency cutoff.

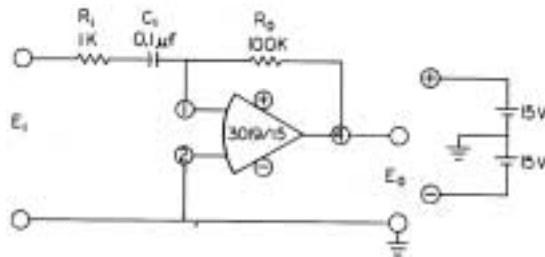

$$E_o = -R_o C_1 \frac{dE_i}{dt}$$

$$= \frac{-1}{100} \frac{dE_i}{dt}$$

high frequency cutoff $F_o = \frac{1}{2\pi R_1 C_1} = .6kc$

low frequency cutoff $F_l = \frac{1}{2\pi R_o C_1} = 16cps$

Low Noise - double high frequency cutoff

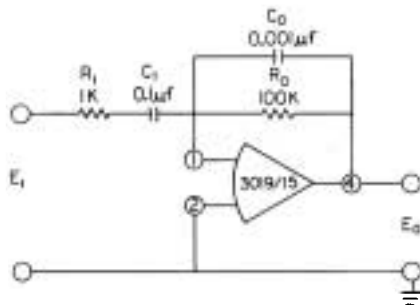

$$R_1 C_1 = R_0 C_0$$

drift compensating resistor

Augmented Differentiator - sums input and its derivative

$$E_o = \frac{-R_o E_1}{R_i} - R_o C_1 \frac{dE_1}{dt}$$

$$E_o = -E_1 - \frac{1}{100} \frac{dE_1}{dt}$$

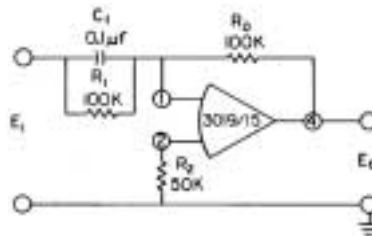

DC AMPLIFIERS

There are two basic circuits, inverting and non-inverting, plus the differential output form. For a fixed or specific minimum gain application, bandwidth may be increased by a simple modification of the operational amplifier. (See Phase Compensation.)

Simple Inverting - sign changing amplifier

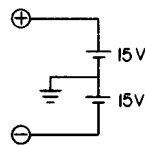
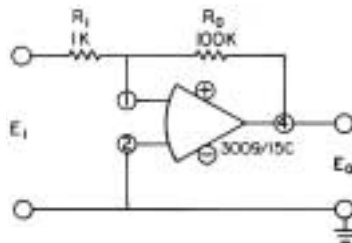

$$E_o = \frac{-R_o}{R_i} E_1 = -100E_1$$

$$\text{resistor} = \frac{R_o R_i}{R_i + R_o} = 1K$$

$$Z_{in} = R_i = 1K$$

Chopper Stabilized - improved drift and stability.

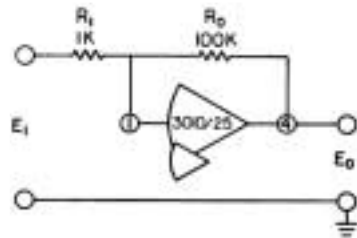

$$E_o = -100E_1$$

Simple Gain Control - wide range or attenuation.

Unity gain with R centered and increases to left.
Gain not linear with R setting.
 Z_{in} drops as gain is increased.

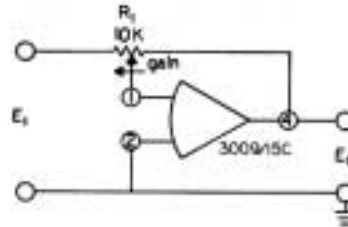

Linear Gain Control

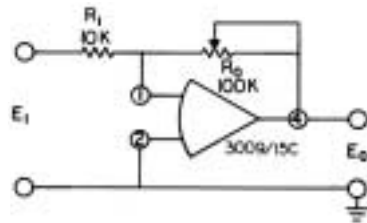

Variable from 0 to 10
 $E_o = 0$ to $-10E_1$
 $Z_{in} = R_1 = 10K$

Simple Non-Inverting - input common mode voltage limit must be observed.

$$E_o = \frac{R_o + R_1}{R_1} E_1 = 10E_1$$

$$Z_{in} > 50 \text{ Megohms}$$

$$Z_{out} < 1 \text{ ohm}$$

Gain controls and/or trimming may be accomplished as in the variations on the inverting amplifier above.

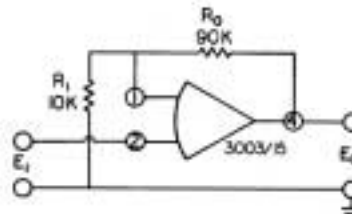

Power Booster - output current of any of the above circuits may be increased by the addition of a power booster. The operational amplifier-booster combination is substituted directly for the original operational amplifier.

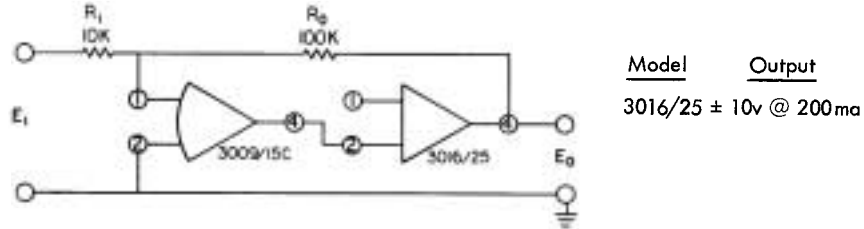

Differential Output - for driving floating load.

$$E_o = \frac{R_o}{R_i} E_i = 10E_i$$

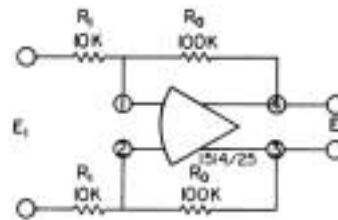

Gain Control - equivalent to replacing both resistors in the non-inverting amplifier by a single potentiometer.

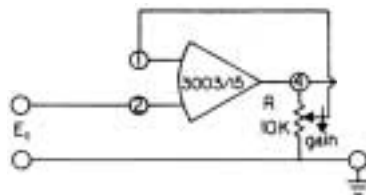

$$E_o = (1 \text{ to infinity}) E_i$$

$$Z_{in} = 50 \text{ Meg}$$

Observe common mode voltage limit.

Inverting Gain Control - convenient gain technique

$$E_o = (-1 \text{ to } -\text{infinity}) E_i$$

$$Z_{in} = 10K$$

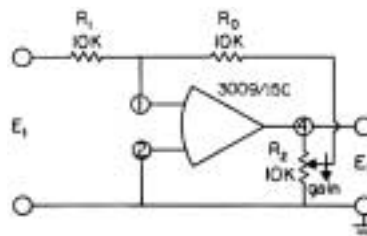

Buffer - $10^{11} \Omega$ input impedance circuit.

$$E_o = \frac{R_o + R_f}{R_f} E_i = 10E_i$$

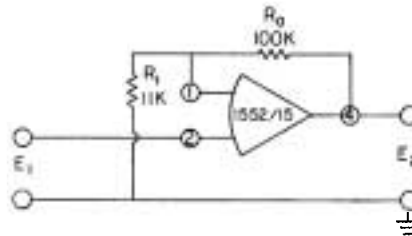

DIFFERENTIAL AMPLIFIERS

In differential amplifiers, separate input signals are applied to the differential inputs of the operational amplifier. The result is direct subtraction in contrast to the summing amplifier which adds algebraically.

Subtractor - direct subtraction of two inputs.

$$E_o = E_2 - E_1$$

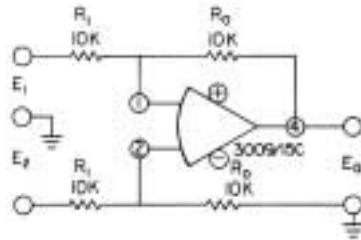

Difference Amplifier - subtractor with amplification.

$$E_o = \frac{-R_o}{R_f} (E_1 - E_2) = 100(E_2 - E_1)$$

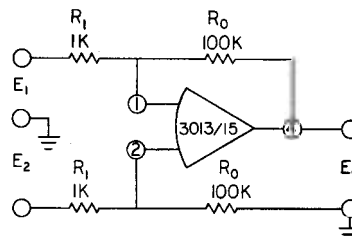

Common Mode Rejection - subtraction by inverting and summing to eliminate common mode voltage.

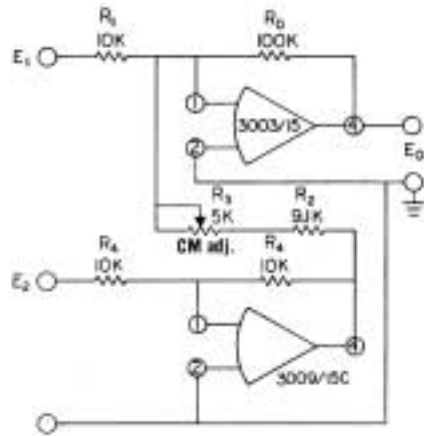

$$E_o = \frac{-R_o}{R_i} (E_1 - E_2) = 10(E_2 - E_1)$$

$$R_2 + R_3 = R_1$$

R_3 - common mode adjustment set for Zero output when $E_1 = E_2$.

Differential Input-Output - for use in driving floating loads.

$$E_o = \frac{R_o}{R_i} (E_2 - E_1) = 10 (E_2 - E_1)$$

Input may be floating source.

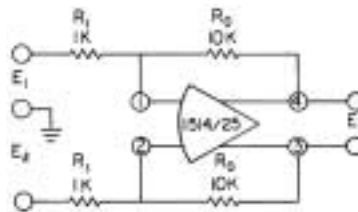

SUMMING AND AVERAGING AMPLIFIERS

Voltages are summed by applying the signals to the same input of the amplifier. Amplifying, averaging, etc., may be accomplished by input resistor scaling. Inputs are effectively isolated from each other. Any number of inputs may be used in each of these circuits.

Adder - output is inverted algebraic sum of inputs.

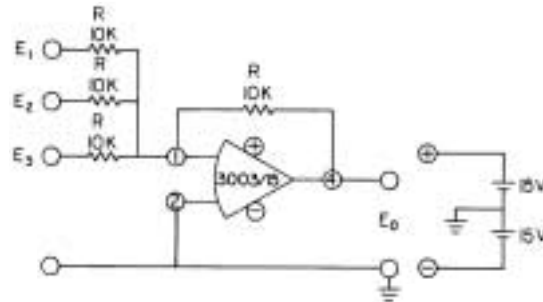

$$E_o = -(E_1 + E_2 + E_3)$$

$$Z_{in} = 10K \text{ for each input}$$

Scaling Adder - each input is multiplied by a constant before summing-inverting output.

$$E_o = -\left(\frac{R_o}{R_1}E_1 + \frac{R_o}{R_2}E_2 + \frac{R_o}{R_3}E_3\right)$$

$$= -(100E_1 + 10E_2 + E_3)$$

$$Z_{in} = 1K \text{ for } E_1$$

$$= 10K \text{ for } E_2$$

$$= 100K \text{ for } E_3$$

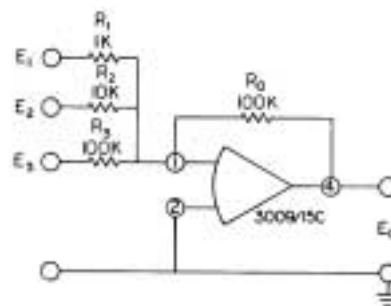

Direct Addition - non-inverting output.

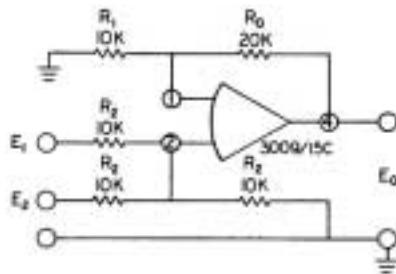

$$E_o = E_1 + E_2$$

$$Z_{in} = \frac{3}{2} R_2 = 15K \text{ for each input}$$

$$R_o = 2R_1$$

Adder Subtractor or Floating Input Combiner - as an adder-subtractor, unused inputs should be grounded.

$$E_o = -E_1 - E_2 + E_3 + E_4$$

R and R₁ not necessarily equal

Two or more "floating" inputs may be combined by connecting them across E₃ to E₁ and E₄ to E₂.

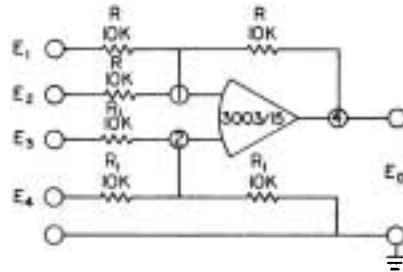

Averager - output is inverted average of input signals. Ground unused inputs to preserve scale.

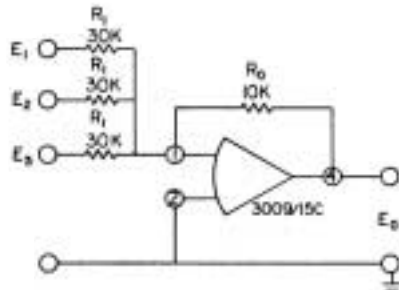

$$E_o = \frac{-R_o}{R_1} (E_1 + E_2 + E_3) = -\frac{E_1 + E_2 + E_3}{3}$$

R_o = R₁ divided by number of inputs

Weighted Average - each input is multiplied by a weighting factor before averaging.

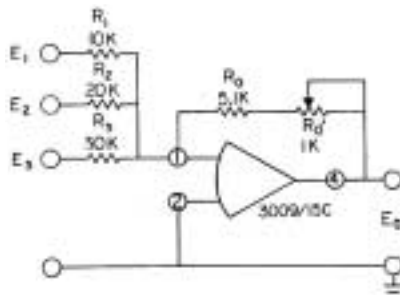

For $E_1 = E_2 = E_3$, set R'_o so $E_o = E_1$

Then, $R_o + R'_o = R_1 \parallel R_2 \parallel R_3$

$$E_o = \frac{-(R_o + R'_o)E_1}{R_1} - \frac{(R_o + R'_o)E_2}{R_2} - \frac{(R_o + R'_o)E_3}{R_3}$$

$$= \frac{-(16.4E_1 + 8.2E_2 + 5.4E_3)}{30}$$

AC AMPLIFIERS

DC Amplifiers with Blocking Capacitors

AC operational amplifier circuits will amplify low frequency signals which are below the range of more conventional amplifiers (0.1cps to 20cps) while DC blocking still is present. High-gain open loop operation is practical. Only a single ended supply is required in one circuit. DC and AC operational amplifier circuits are equivalent at higher frequencies.

Simple Amplifier - simple RC roll off at low frequency.

$$E_o = -\frac{R_o}{R_i} E_1 = -10E_1$$

Low frequency rolloff begins

$$= \frac{1}{2\pi R_i C_1} = 16\text{cps}$$

$$Z_{in} = 10K$$

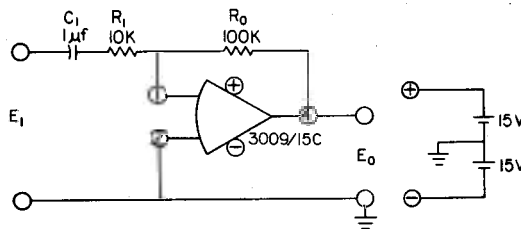

Single Supply - equivalent to above with the supply "floated" above ground.

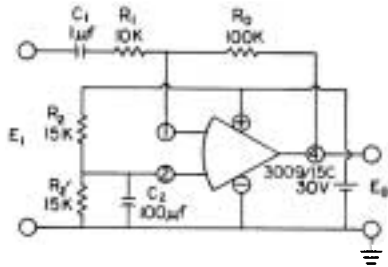

C₂ - AC bypass

High Gain - AC open loop operation

Low frequency rolloff begins at 1Kc

(where $\frac{X_{C1} + R_o}{X_{C1}}$ = open loop gain)

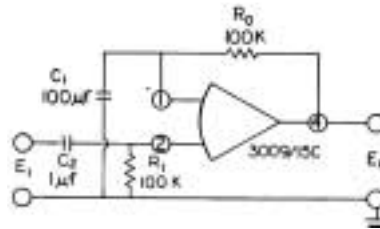

"Non-Inverting" - E_o in phase with E

$$E_o = \frac{R_o + R_1}{R_1} = 10E_1$$

Low frequency rolloff begins

$$= \frac{1}{2\pi R_1 C_1}$$

$$= 0.16\text{cps}$$

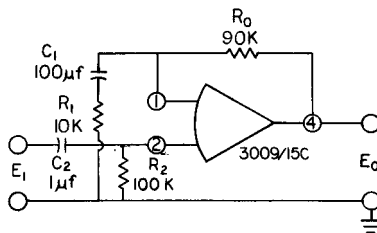

Double Rolloff - similar to above.

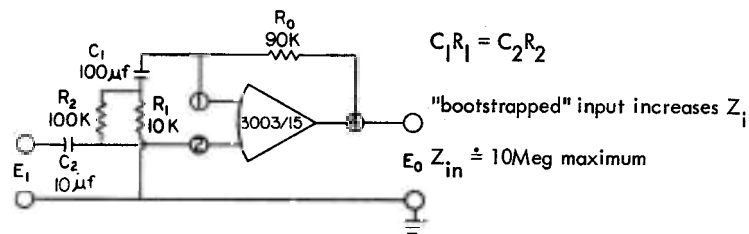

AC Preamplifier - completely developed AC amplifier with high Z_{in} and double rolloff rate and gain trim.

$$\frac{E_o}{E_i} = \frac{R_o + R_1}{R_1} = 500$$

R_4 - Fine gain adjust

Low frequency rolloff begins

$$= \frac{1}{2\pi R_1 C_1} = 1.6 \text{ cps}$$

$$R_1 C_1 = R_2 C_2$$

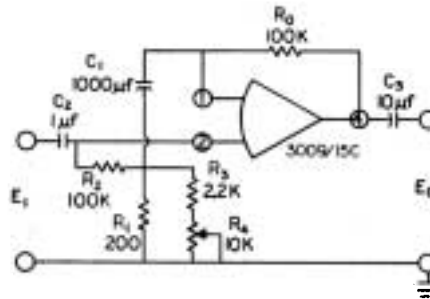

CURRENT OUTPUT DEVICES

These amplifiers will supply output current to a load in linear correspondence to the input voltage.

Feedback Loop

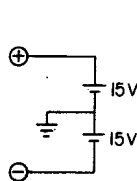
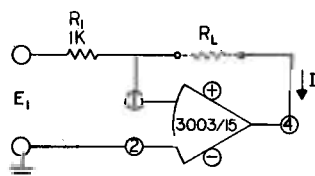

$$I = \frac{E_1}{R_1} = E_1 \text{ ma}$$

$$Z_{in} = R_1 = 1K$$

Simple Meter Amplifier - linear current meter reads AC input voltage.

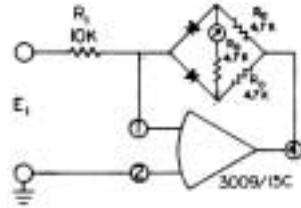

$$I_{\text{meter}} = \frac{E_1}{3R_1} = \frac{E_1}{30} \text{ ma}$$

Meter Amplifier - fully developed average reading meter.

$$I_{\text{meter}} = \frac{E_1}{R_4 + R_5}$$

$$I_{\text{m(average)}} = \frac{0.9E_1}{R_4 + R_5} \text{ (rms)}$$

R_5 - gain control, calibrate

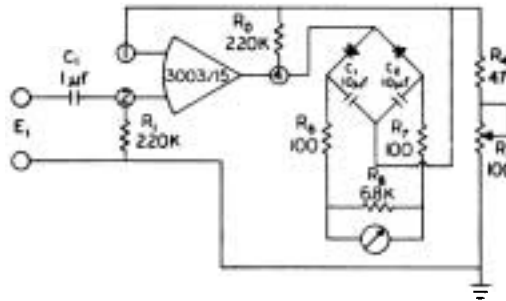

Current Injector - single terminal current available to ground.

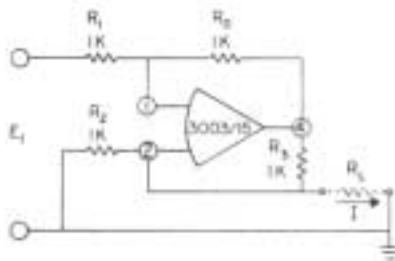

$$I = -\frac{E_1}{R_1 R_2} = -E_1 \text{ ma}$$

$$\frac{R_1}{R_2} = \frac{R_4}{R_3}$$

Observe common mode voltage limit

Linear Current Source

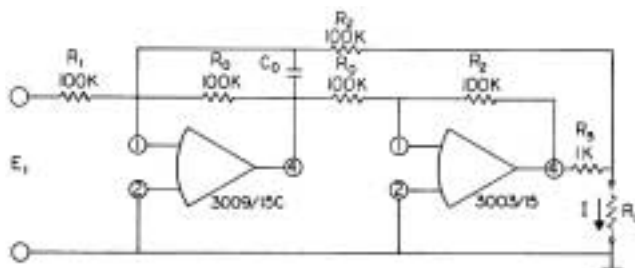

When $R_L \ll R_2$, $I_L = \frac{R_2}{R_1 R_3} E_1 = \frac{1 \text{ ma}}{\text{volt}}$

Change R_3 for current scaling

R_3	I_L / E_1
1K	1ma/volt
100	10ma/volt
10	100ma/volt

C_0 added for high frequency stability.

Deflection Coil Driver - load must be "floating," i.e. ungrounded.

$I = \frac{-R_0}{R_1 R_3} E_1 = -100 \text{ ma/volt}$

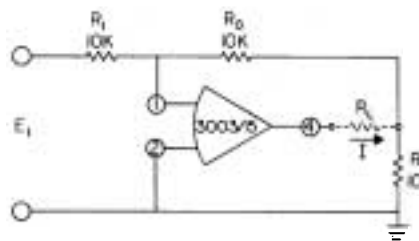

OSCILLATORS AND MULTIVIBRATORS

Oscillators give a continuous sine wave output. Multivibrator output is: fixed voltage level or square wave similar to flip-flop output.

Simple Oscillator - double integrator circuit with regenerative feedback.

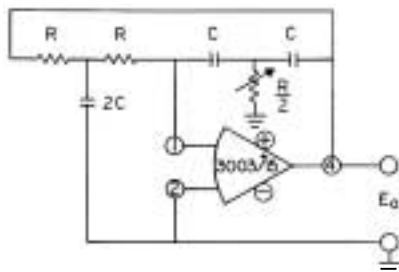

$f = \frac{1}{2\pi RC}$

Components R, C, and 2C should be very low tolerance

Trim R/2 until oscillation is barely sustained

Wien Bridge Oscillator - high purity sine wave generation.

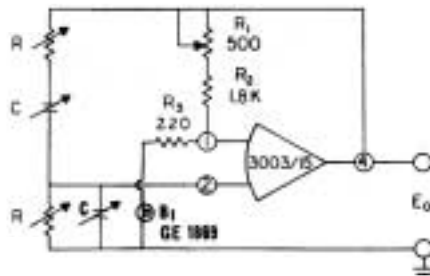

$$f = \frac{1}{2\pi RC}$$

100 - 6,000cps

Astable Multivibrator - "free-running" flip-flop action may be locked in to some external sync signal or left free.

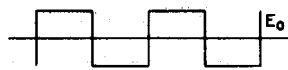
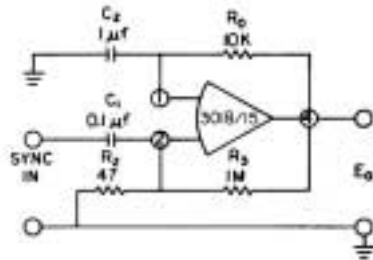

Frequency set by C₂ and R₂

Bistable Multivibrator - flip-flop or memory device for AC or trigger pulse input.

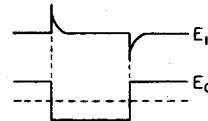
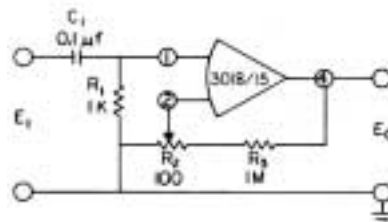

R₂ - triggering level

Monostable Multivibrator - astable multivibrator with diode to prevent triggering in reverse direction or reset action. Use Model 3018/15 with phase compensation removed.

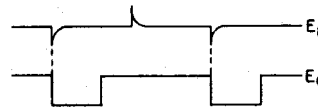
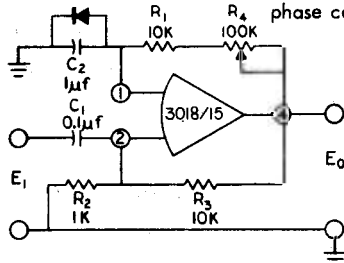

R₄ - output duration

PHASE LEAD AND LAG NETWORKS

These networks are used to stabilize servo systems by introducing phase shift as desired. Transient and steady state responses may be tailored semi-independently.

Lag Element - integrating type phase lag.

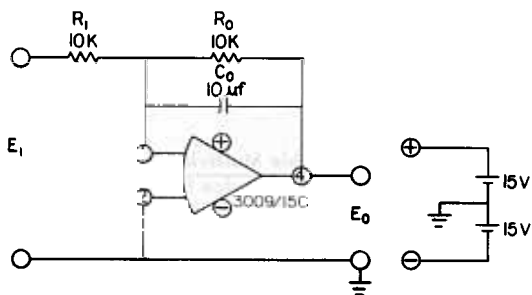

$$E_o = \frac{-R_o}{R_1} \frac{E_1}{1 + R_o C_o P}$$

$$= \frac{-10 E_1}{10 + P}$$

Adjustable Lag - non-integrating type.

Constant inverting unity gain

Maximum lag for R_1 centered for $\Delta = \frac{1}{2}$
 where $0 \leq \Delta \leq 1$ is the lag setting.

$$E_o = \frac{-E_1}{1 + (\Delta - \Delta^2) RCP} = \frac{-40 E_1}{40 + P}$$

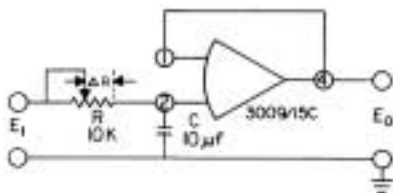
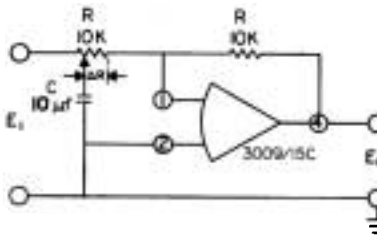

Lag value linear with R setting

Non-inverting low distortion

For = maximum

$$E_o = \frac{E_1}{1 + \Delta RCP} = \frac{10 E_1}{10 + P}$$

P = operator, $\frac{d}{dt}$ or $j\omega$

Adjustable Lead - putting input network from adjustable lag circuit in feedback path gives lead element.

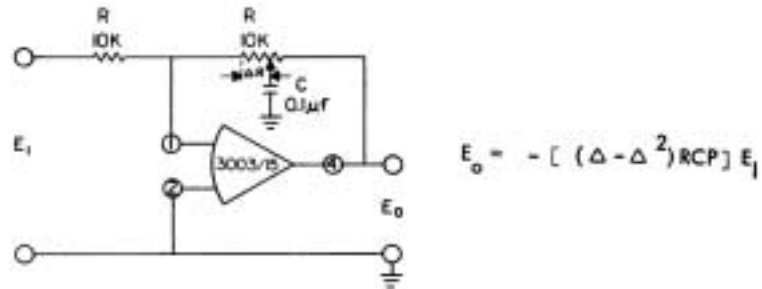

Lead-Lag - composite lead and lag networks.

$$E_o = - \frac{1 + (\Delta_1 - \Delta_1^2) R C_1 P}{1 + (\Delta_2 - \Delta_2^2) R C_2 P}$$

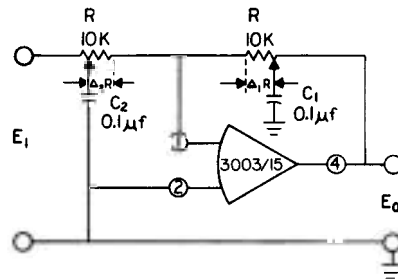

Time Delay - unity gain phase or time shift.

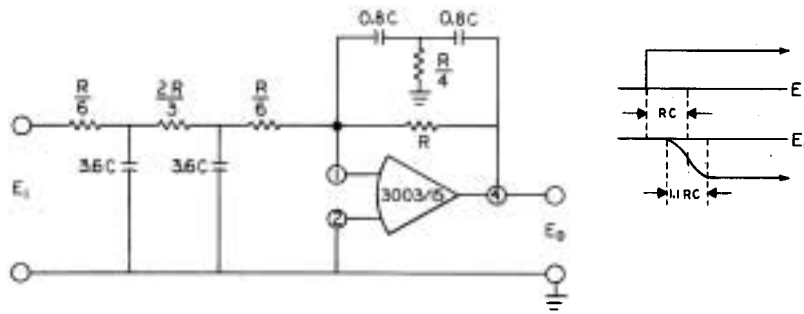

ADDITIONAL CIRCUITS

The following are various circuits which do not fall into one of the categories of the previous sections.

Absolute Value - full wave rectification

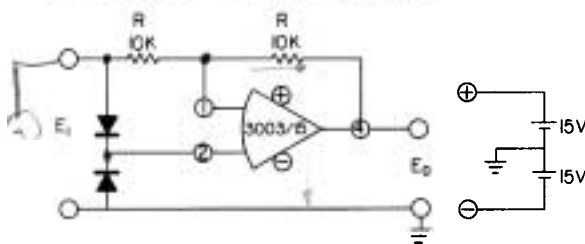

+E₁ follower circuit

-E₁ inverter circuit

$$E_o = |E_1|$$

Reverse diodes to give

$$E_o = -|E_1|$$

Null Detector - wide sensitivity range.

Non-linear resistance, R₀, increases as E₁ decreases giving maximum gain near E₁ = 0 for precise null indication.

Thyrite varistor GE 839683961

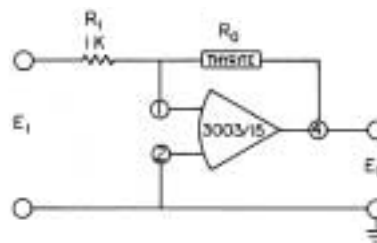

Peak Follower - peak value memory. Use low leakage capacitor.

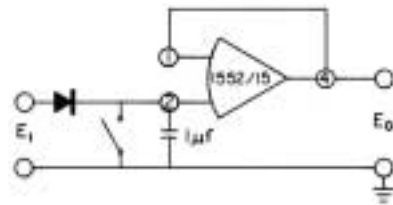

$$E_o = E_i \text{ maximum}$$

Common mode input voltage must be observed.

Precision Rectifier - half wave with amplification if desired. Placing rectifiers in feedback loop decreases non-linearity to very small value.

$$E_o \text{ peak} = \frac{-R_o}{R_i} E_i \text{ peak} \approx -5E_i \text{ peak}$$

+ 5E_o peak

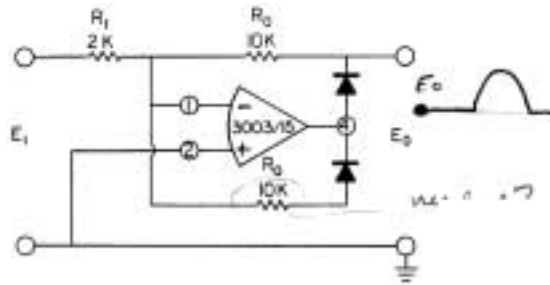

AC to DC Converter - precision conversion for measurement or control

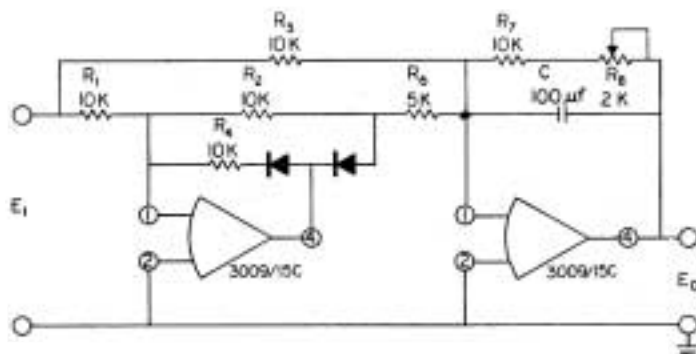

0.9 E_i ms

$$E_o \text{ average} = E_i \text{ rms}$$

$$E_{in} = 6\text{mv to } 6\text{v rms } @ 10\text{-}1000\text{cps}$$

Full wave rectifier with a smoothing filter.

Go - No Go - amplitude discriminator

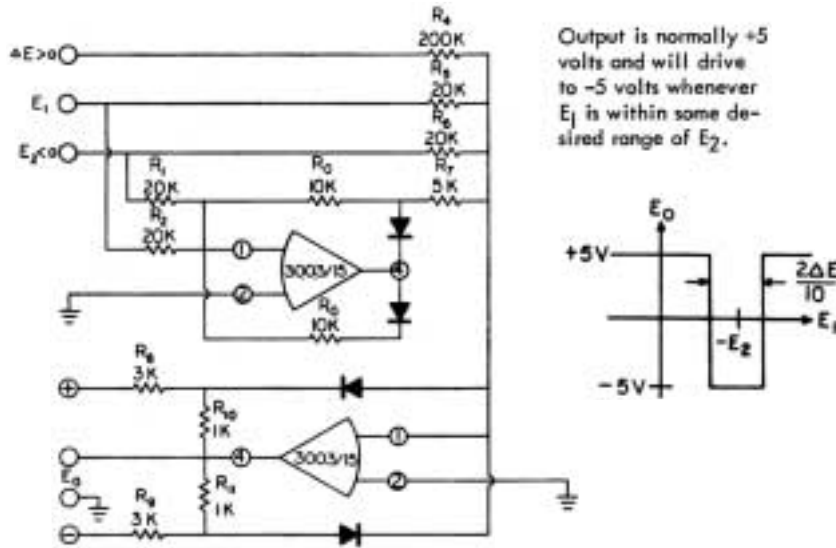

Rate Limiter

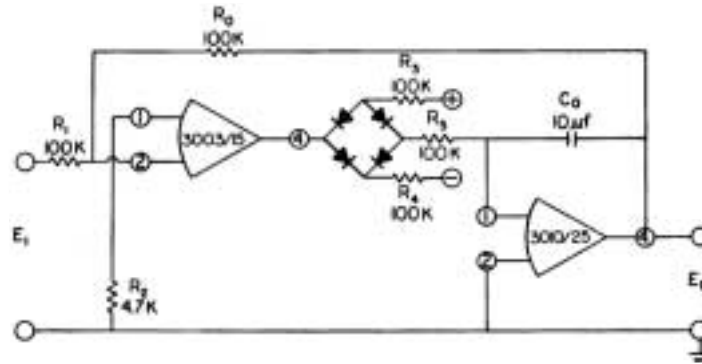

$$E_o = \frac{-R_o}{R_i} E_i = -E_i \quad \text{Rate limit} = \frac{E_{\text{supply}}}{C_0} = 7.5\text{v/sec}$$

Time Delay - time operated relay.

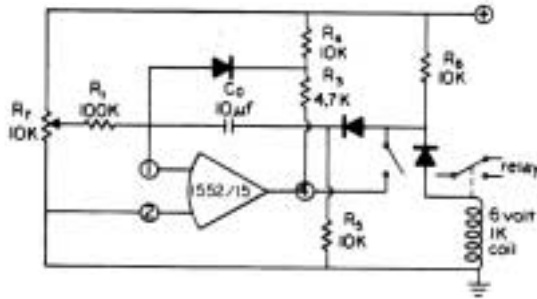

$$\text{Delay} = \frac{R_1 C_0}{2K_1}$$

Where K is setting of R_1 , $0 < K < 1$

Open switch to reset, close to being timing.

Selective Amplifier - Twin T feedback.

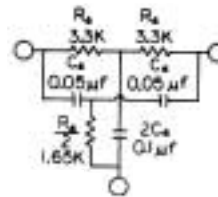
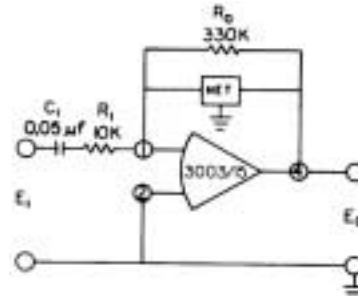
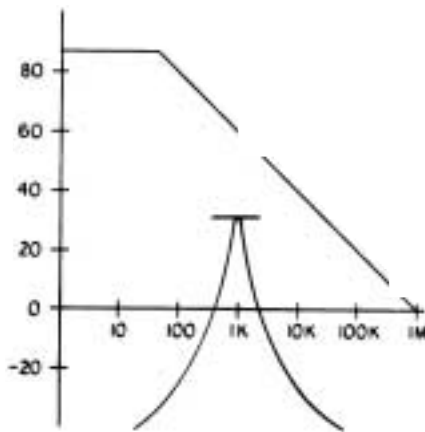

$$\text{Frequency peak} = \frac{1}{2\pi R_0 C_0} = 1000\text{cps}$$

Set C_1 so that $C_1 R_1 > 2C_0 R_0$ and $R_1 < 100K$

$$Z_{in} \approx R_1 = 10K$$

$$\text{Gain at peak} \approx \frac{R_0}{R_1} = 33 \approx 30\text{db}$$

$$Z_{out} < 200 \text{ ohms}$$

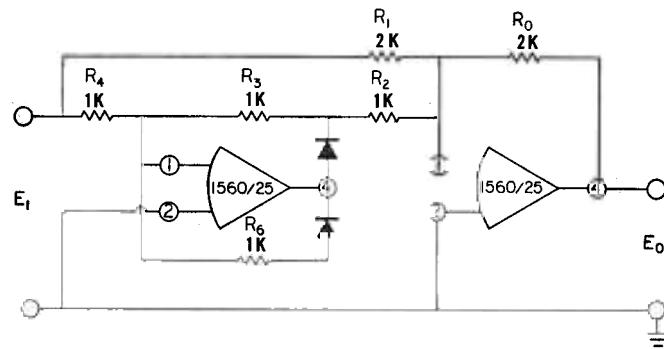
Full Wave Rectifier - precision absolute value circuit

APPENDIX A

REFERENCES

The literature has many references to the topics in the field of active RC circuits which have been introduced in this handbook. Some of these are given in the list that follows. No attempt has been made to make this an all inclusive list; rather it is presented to give the interested reader a starting place in his pursuit of more detailed information on this subject. The references are arranged by chapter.

Chapter 1

A general theoretical treatment of the subject of active networks, together with many additional realization techniques may be found in the book by K. L. Su, *Active Network Synthesis* McGraw-Hill Book Co., Inc., New York, 1965

Chapter 2

General design formulas for several types of bridged-T and twin-T networks, as well as a general discussion of the synthesis of passive RC networks may be found in the book by N. Balabanian, *Network Synthesis*, Chap. 7, Prentice-Hall, Inc., Englewood Cliffs, New Jersey, 1958. A more detailed presentation of several cases, together with several design charts may be found in Appendix VI of the book by C. J. Savant, Jr., *Control System Design*, 2nd Ed., McGraw-Hill Book Co., Inc., 1964

A simplified method for the design of twin-T networks with transmission zeros in the right-half of the complex frequency plane may be found in the article by B. A. Sheno, "A New Technique for Twin-T RC Network Synthesis," *IEEE Transactions on Circuit Theory*, Vol. CT-11, No. 3, pp. 435-436, Sept. 1964

A discussion of the adjustment problem in twin-T networks may be found in the article by K. Posel, "A New Treatment of the RC Parallel-T Network," *Proceedings of the Institution of Electrical Engineers (England)*, Vol. 110, No. 1, pp. 126-138, Jan. 1963.

Chapter 3

A tabular method which may be used to determine the voltage transfer function of a network using a fairly arbitrary feedback network is given in the article by A. G. J. Holt and J. Sewell, "Table for the Voltage Transfer Functions of Single-Amplifier Double-Ladder Feedback Systems," *Electronics Letters* (published by the Institution of Electrical Engineers, England), Vol. 1, No. 3, pp. 70-71, May 1965

A design method for a third order filter using a single operational amplifier is given in the article by L. K. Wadhwa, "Simulation of Third-Order Systems with Double-Lead Using One Operational Amplifier," *Proceedings of the IRE*, Vol. 50, No. 6, pp. 1538-1539, June 1962. Articles on similar filters with different zeros may be found in the February and April Proceedings issues of the same year.

Chapter 4

The classic article in this area is the one by R. P. Sallen and E. L. Key, "A Practical Method of Designing RC Active Filters," *IRE Transactions on Circuit Theory*, Vol. CT-2, No. 1, pp. 74-85, March 1955. Some additional circuits are given in the article by N. Balabanian and B. Patel, "Active Realization of Complex Zeros," *IEEE Transactions on Circuit Theory*, Vol. CT-10, No. 2, pp. 299-300, June 1963

Chapter 5

The properties of a negative-immittance converter as a two-port device were defined by A. I. Larky, "Negative-Impedance Converters," *IRE Transactions on Circuit Theory*, Vol. CT-4, No. 3, pp. 124-131, September 1957. In addition to the circuit for an NIC given in the Larky paper, several other circuit realizations have appeared in the literature. See, for example, D. P. Franklin, "Direct-Coupled Negative-Impedance Converter," *Electronics Letters*, Vol. 1, No. 1, p. 1, March 1965. Power and impedance transformation properties are discussed by L. P. Huelsman, "A Fundamental Classification of Negative-Immittance Converters," *1965 IEEE International Convention Record*, Part 7, pp. 113-118, March 1965.

The basic circuit for the realization of a voltage transfer with an INIC presented in this chapter is described in more detail by T. Yanagisawa, "RC Active Networks Using Current Inversion Type Negative Impedance Converters," *IRE Transactions on Circuit Theory*, Vol. CT-4, No. 3, pp. 140-144, Sept. 1957. Another basic approach that uses VNICs is given by J. G. Linvill, "RC Active Filters," *Proceedings of the IRE*, Vol. 42, No. 3, pp. 555-564, March 1954.

Chapter 6

Books which cover the topics of this chapter are the ones by Su (see Chapter reference) and L. P. Huelsman, *Circuits, Matrices, and Linear Vector Spaces*, McGraw-Hill Book Co., Inc., New York, 1962.

APPENDIX B

DESCRIBING ACTIVE FILTERS

This handbook is addressed primarily to the design of active RC circuits employing operational amplifiers as the active elements. While we have seen that the operational amplifier is extremely versatile in active filter applications, it none-the-less holds true that for every requirement there is one operational amplifier which provides the optimum performance and value. It is, therefore, important for the user to work closely with a reputable manufacturer of operational amplifiers to gain the flexibility of being able to tailor an amplifier to the filter requirement. To fully utilize this service, it becomes necessary for the user to describe his filter requirement.

Describing the Filter

There are many ways to describe a particular active filter. If you have evaluated a circuit from this handbook, referencing the page number along with the amplifier and circuit values employed provides a good starting point for the manufacturer. Any problems or limitations encountered should also be noted.

The shape of the transfer function should be described by function (low pass, band pass, band rejection, high pass), pass-band gain, frequency response (3 dB points or accuracy over range of interest), roll-off characteristics (dB/octave or dB/decade or rejection at specific frequencies), and type (Butterworth-maximally flat, Bessel-linear phase, Tchebyscheff-equal ripple, etc.). Alternatively, the filter may be described in terms of the basic function of the filter and overall system, a pole-zero plot, or a plot of the desired response versus frequency. Usually some combination of the above method is best used to describe a particular filter.

Optimizing the Circuit

Given a complete description of the active filter requirement, the amplifier manufacturer can begin to make some very interesting design trade-offs. In some band pass and high pass circuits it may be possible to relax the DC voltage and current offset and stability requirements which normally add to the cost of operational amplifiers. In certain filter circuits, the RC phase compensation network inside the operational amplifier may be modified to allow higher frequency performance. Thus, it is often desirable to wed the active amplifier and passive filter elements into a single committed active filter module. The resulting optimized circuit usually provides higher performance at lower overall cost than either a filter employing "standard" amplifiers or a "standard" active filter which must be customized at least in terms of cut-off frequencies for your application.

Limiting Specifications

The final filter design can be completely described by electrical, mechanical, and environmental specifications. In the design stage, however, it is important to indicate the critical or limiting specifications so as not to unduly restrict the design or add to the design and product cost, and to help resolve any conflicting specifications or design trade-offs.

Conclusion

A reputable manufacturer of operational amplifiers with experience and competence in active filters offers valuable services to the user. Whether the service takes the form of circuit consultation, amplifier recommendation, special amplifier design, special filter design, or the supplying of a standard filter, the user must furnish a complete description of his filter requirements.

APPENDIX C

SPECIFICATIONS

Typical Burr-Brown Operational Amplifiers

The specifications shown in Table 1 and Table 2 (on the following page) are indicative of: (1) the complexity of operational amplifiers, (2) the state of the art in operational amplifiers as of the publishing date of this handbook, and (3) the extensive line of operational amplifiers manufactured by Burr-Brown Research Corporation. Complete specifications are available on request.

TABLE

Performance at 25°C and with rated supply.

	3003/15	3055/01	1901/19 (1)	3062/15	3061/15	3013/15 (2)	Units
RATED OUTPUT Voltage (min) Current (min)	+ 10 ± 20	± 10 ± 5	± 10 ± 20	± 10 ± 100	± 4 ± 5	± 10 ± 20	V mA
DC GAIN (typ)	110	94	106	95	100	92	dB
UNITY GAIN Crossover (typ)	2	1	1.5	15	0.8	10	MHz
FULL POWER RESPONSE (min)	20	20	20	1000	5	500	kHz
SLEWING RATE (min)	1.2	1.2	1.2	60	0.1	30	V/μs
INPUT VOLTAGE Offset, 25°C (typ) (4) Average Drift, -25°C to +85°C (typ) (max)	+0.2 ± 1 ± 3	+ 1 ± 2 ± 5	+0.3 ± 5 ± 10	+ 0.5 ± 10 ± 25	+0.3 ± 5 ± 10	+ 0.5 ± 10 ± 15	mV μV/°C μV/°C
INPUT CURRENT Offset, 25°C (typ) Drift, -25°C to +85°C (typ) (max)	+ 5 ±0.1 ±0.3	±200 ±0.3 ±0.6	± 5 ±0.2 ±0.5	± 0.1 Note 7 Note 7	± 5 ±0.3 ±0.5	+0.02 Note 7 Note 7	nA nA/°C nA/°C
INPUT NOISE TO 10 kHz (typ)	3	3	5	6	1 ⁽²⁾	6	μV rms
INPUT IMPEDANCE Differential (typ) Common Mode (typ)	0.5 50	0.3 200	0.5 50	10 ¹¹ Ω 10 ¹¹ Ω	1 50	10 ¹¹ Ω 10 ¹¹ Ω	M Ω M Ω
INPUT VOLTAGE LIMITS Common Mode (max) Absolute Maximum	± 10 ± 15	± 11 ± 15	± 10 ± 15	± 10 ± 15	± 4 ± 10	± 10 ± 15	V V
OUTPUT IMPEDANCE (typ)	5	4	5	0.01	5	5	k Ω
OPERATING TEMPERATURE RANGE Minimum Maximum	+ 40 + 85	+ 25 + 85	+ 40 + 85	+ 40 + 85	+ 40 + 85	+ 40 + 85	°C °C
POWER SUPPLY Rated (typ) (4) Quiescent (max) (5)	+ 15 ± 5	± 15 ± 6	± 15 ± 5	± 15 ± 12	± 6 ± 1	± 15 ± 8	Vdc mA
BASIC MODULE TYPE (8)	/15	/01	/19	/15	/15	/15	

Notes: Specifications subject to change without notice.

- (1) Model 1901 has been certified under MIL-STD-202C and MIL-STD-810 for humidity, altitude, shock, acceleration, thermal shock and vibration.
- (2) Dc to 1 kHz.
- (3) The settling time for Model 3013 is less than 1.5 μsec.
- (4) Range: ± 12 Vdc to ± 18 Vdc.
- (5) Total current approximately equal to quiescent plus output current.
- (6) Externally adjustable to zero. Alternate /13, /16 and /26 modules feature internal voltage offset adjustment.
- (7) Input current doubles every 10°C rise.
- (8) See mechanical data for alternate module types.

APPENDIX C (continued)

TABLE 2

Performance at 25°C with rated supply.

	3071/25	1540/15	1541/25	1545/25	1706/17	1552/15	Units
RATED OUTPUT Voltage (min) Current (min)	+ 10 + 20	+ 20 + 10	+ 30 + 10	+100 + 10	+ 10 + 10	+ 10 + 20	V mA
DC GAIN (typ)	150	106	110	110	106	106	dB
UNITY GAIN Crossover (typ)	15	1.5	0.4	1.0	2	2.0	MHz
FULL POWER RESPONSE (min)	1000	10	3	20	20	100	kHz
SLEWING RATE (min)	60	1.2	0.9	12	1.2	6	V/μs
INPUT VOLTAGE Offset, 25°C (typ) (1) Drift, -25°C to +85°C (typ) (max)	+0.01 + 0.2 ± 0.5	+0.3 + 5 ± 10	+0.2 + 10 ± 25	+0.5 + 10 ± 25	+0.5 + 5 ± 15	+ 0.5 + 5 ± 15	mV μV/°C μV/°C
INPUT CURRENT Offset, 25°C (typ) Average Drift, -25°C to +85°C (typ) (max)	+0.02 ±0.0005 +0.001	+ 10 ±0.3 +0.5	+ 10 ±0.5 +1.0	+0.1 Note 4 +1.0	+ 5 +0.2 +0.5	+0.02 Note 4 Note 4	nA nA/°C nA/°C
INPUT NOISE TO 10 kHz (typ)	2 ⁽⁵⁾	3	10	10	3	6	μV rms
INPUT IMPEDANCE Differential (typ) Common Mode (typ)	0.5 —	0.5 100	0.5 100	10 ⁽¹⁾ Ω 10 ⁽¹⁾ Ω	0.5 50	10 ⁽¹⁾ Ω 10 ⁽¹⁾ Ω	MΩ MΩ
INPUT VOLTAGE LIMITS Common Mode (max) Absolute Maximum	— + 15	+ 15 + 26	+ 20 + 60	+ 20 + 60	+ 10 + 15	+ 10 + 15	V V
OUTPUT IMPEDANCE (typ)	5	5	5	30	5	0.5	Ω
OPERATING TEMPERATURE RANGE Minimum Maximum	- 40 + 85	- 40 + 85	- 40 + 85	- 40 + 85	- 40 + 85	- 40 + 85	°C °C
POWER SUPPLY Rated (typ) (2) Quiescent (max) (3)	+ 15 + 10	+ 26 + 5	+ 60 + 10	+120 + 7	+ 15 + 5	+ 15 + 8	Vdc mA
BASIC MODULE TYPE (2)	/25	/15	/25	/25	/17	/15	

Notes: Specifications subject to change without notice.

- (1) Externally adjustable to zero. Alternate /13, /16 and /26 modules feature internal voltage offset adjustment.
- (2) Range: ± 3 volts of typical for ± 15 and ± 26 volt supplies, ± 5 volts of typical for ± 60 and ± 120 volt supplies.
- (3) Total current approximately equal to quiescent plus output current.
- (4) Input current doubles every 10°C rise.
- (5) See mechanical data for alternate module types.
- (6) 6 Hz to 1 kHz.

APPENDIX C (continued)

TABLE 3
MODEL 3016/25 Power Booster

Rated Output		DC Gain D.L.	Operating Temperature Range		Power Supply	
v _o ls	mA		min	max	v _o lts	quies
min	max	typ	°C	°C	typ	max
±10	±200	0	-40	+85	±15	±13

TABLE 4
MODEL 1515/25 Dual Regulator

Rated Output		Input Voltage		
v _o lts	mA	nominal	min	max
min	max			
±15	±100	±26	±20	±32

TABLE 5
MODEL 501 Dual Power Supply

Type	Dimensions	Rated Output
module	3 1/2" x 3" x 2"	±15V @ ±120mA

FOR /01 MODULES

MATING CONNECTOR accommodates all monolithic integrated circuit amplifiers. Barnes MF-15-8B

FOR /15, /15C, /25, /29 and /40 MODULES

MATING CONNECTOR (as shown) accommodates all these operational amplifiers for plug-in installation or test. Model 1500MC

MATING CONNECTOR is similar to the 1500MC for mounting dual regulators. Model 1500MC-1

MATING CONNECTOR for encapsulated multipliers is similar to the 1500MC. Order Model 1500MC-4

FEEDBACK BOARD provides solder terminals for feedback components. Model 1500FB

CIRCUIT SIMULATOR (as shown) is a patch panel with 3/4" spaced jacks for feedback elements. Includes offset control. Accommodates all operational amplifiers and adapters having standard 8-pin configuration. Model 1500CS

FOR /17 MODULES

MATING CONNECTOR (as shown) accommodates all /17 modules for plug-in installation. Model 1700MC

ADAPTER PLUGS allow use of /17 units on 1500CS Circuit Simulator. Model 1700AP (for Model 1701). Model 1700AP-1 (for all other /17 units)

FOR /19 MODULES

MATING CONNECTOR (as shown) accommodates all /19 operational amplifiers. Model 1900MC. For Model 9874 and 9875 squaring modules use the Model 1900MC-1

ADAPTER PLUG allows use of 1500CS Circuit Simulator. Model 1900AP

FOR /16 MODULES

RACK ADAPTER holds 16 units in a 3-1/2" x 19" rack space. Model 1600-16R

WIRED RACK ADAPTER is identical to the 1600-16R but includes mating connectors and power bus wire. Model 1600-16RW

HALF RACK ADAPTER holds 7 units in a 3-1/2" x 9-1/2" rack space. Model 1600-7R

POWERED RACK ADAPTER - See Power Supplies, 506/16, 507/16, 508/16, 509/16.

MATING CONNECTOR (Bumdy EC4206P5) is furnished with unit. Extra connectors

BLANK PANEL provides uniform appearance of the rack. Model 1600 BP

CARD EXTENDER allows testing without disconnecting unit from rack. Model 1600CE

BLANK MODULE is the same enclosure as the /16 module. Terminals for each pin are mounted next to the connector on the printed circuit board. Model 1600M

FOR /16-2 MODULES

BLANK MODULE is similar to the /16 with the exception of double width. Model 1600M-2

MATING CONNECTOR same as /16 is furnished with unit. Extra connectors

FOR /26 MODULES

RACK ADAPTER holds 16 units in 3-1/2" x 19" rack space. Model 2600-16R

MATING CONNECTOR (Amphenol 14J-012-01) is furnished with unit. Extra connectors

BLANK MODULE is the same enclosure as the /26 module. Terminals for each pin are mounted next to the connector on the printed circuit board. Model 2600M

BURR-BROWN ACTIVE FILTERS

These low-pass active filter modules, Models 5001/29 and 5011/29, provide maximally-flat response (Butterworth) with 60 dB per decade rolloff above the 3 dB frequency (f_c). Fixed bandpass gain and fixed cutoff frequency (f_c) may be specified within the wide ranges indicated. Because of the high input impedance (more than 10 k Ω), the low output impedance (less than 10 Ω), and the gain (± 0.5 to ± 200 V/V), these units can function both as filters and amplifiers in your circuit designs.

These low-pass active filter modules, Models 5002/29 and 5012/29, provide equal ripple response (Tchebyscheff). The initial rolloff rate is increased as the specified maximum ripple is increased. Cutoff frequency (f_c) is defined as the point on the frequency response curve at which the response is down by the amount of the allowable ripple; that is, 1 dB down for a 1 dB maximum ripple filter.

Special order active filters for low-pass (LP), high-pass (HP), band-pass (BP), and band rejection (BR) applications are all available from Burr-Brown. Our applications staff is uniquely qualified to discuss your particular requirements.

SPECIFICATIONS

Description	BUTTERWORTH RESPONSE	TCHEBYSCHIEFF RESPONSE	SPECIAL RESPONSE
Models	Model 5001/29 (inverting) Model 5011/29 (non-inverting)	Model 5002/29 (inverting) Model 5012/29 (non-inverting)	Custom
No. of Poles	3	3	2 to 7
Characteristic	Max. Flat (Butterworth)	Equal Ripple (Tchebyscheff)	As Required (Describe)
Pass Band Gain	-6dB to +46dB	-6dB to +46dB	-20dB to +60dB
Cutoff Frequency	5 Hz to 20 kHz	5 Hz to 20 kHz	0.1 Hz to 100 kHz
Frequency Stability	$\pm 0.05\%/^{\circ}\text{C}$	$\pm 0.05\%/^{\circ}\text{C}$	± 0.01 to $1\%/^{\circ}\text{C}$
Roll-off Rate	60dB/decade	60dB/decade	40 to 140dB/dec.
Maximum Ripple	± 0.1 dB	± 0.5 to ± 3 dB	± 0.1 to ± 3 dB
Input	Single Ended	Single Ended	Single Ended
Input Impedance	10k Ω min.	10k Ω min.	1k Ω to 10M Ω
Output Offset	Ext. Adj. to 0	Ext. Adj. to 0	Ext. Adj. to 0
Output Swing	± 10 V	± 10 V	± 4 V to ± 100 V
or Output Current	± 10 mA	± 10 mA	± 1 mA to ± 50 mA
Rated Power Supply	± 15 V	± 15 V	± 6 V to ± 120 V
Range	± 12 V to ± 18 V	± 12 V to ± 18 V	As Required
Quies. Current	± 10 mA	± 10 mA	As Required
Operating Temperature	-25°C to $+85^{\circ}\text{C}$	-25°C to $+85^{\circ}\text{C}$	As Required
Module Type	/29	/29	As Required

MECHANICAL DATA

/13 PACKAGE

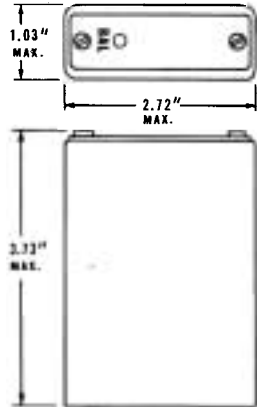

Typical Mounting
 Connector Burndy EC 4205-P5
 Applies to /13 Package and /16 Package

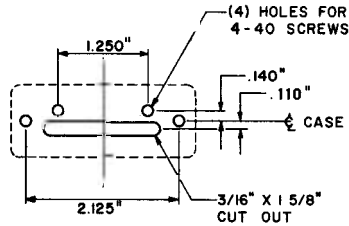

/15 PACKAGE

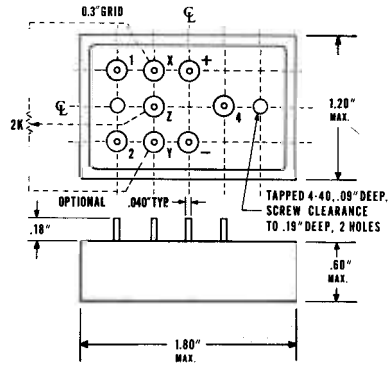

/25 PACKAGE

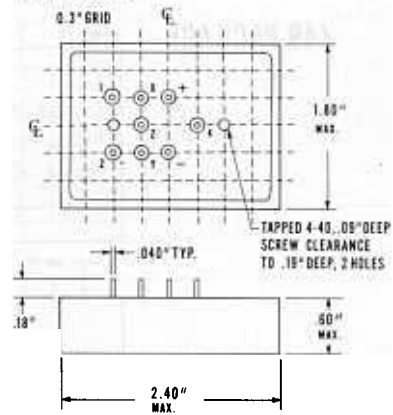

/16 PACKAGE

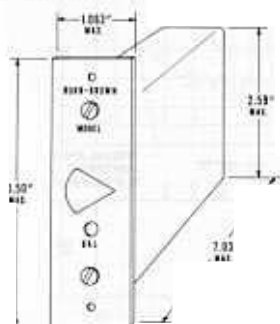

/16-2 PACKAGE

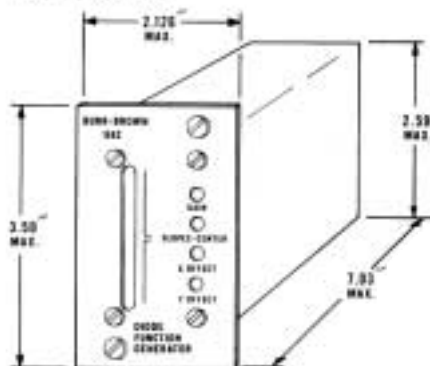

MECHANICAL DATA (continued)

/17 PACKAGE

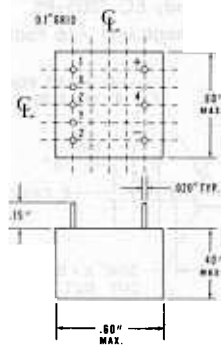

/19 PACKAGE

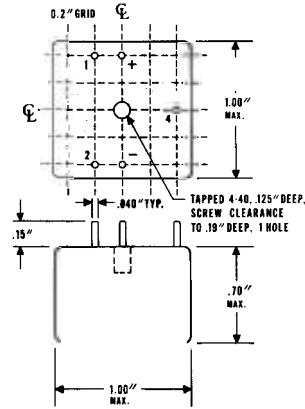

/49 PACKAGE

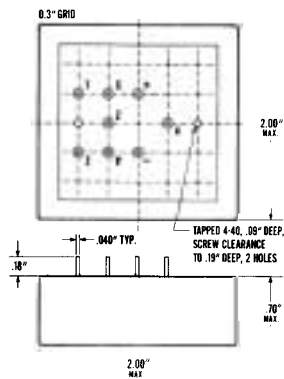

/29 PACKAGE

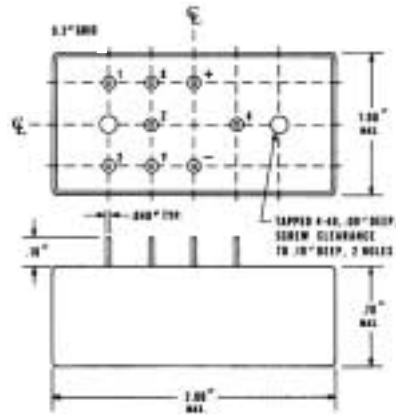

/40 PACKAGE

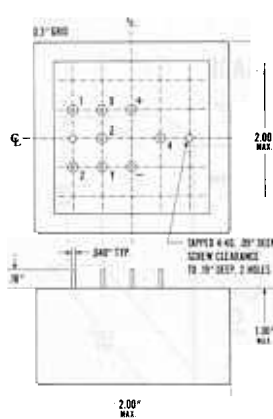

APPENDIX D

REACTANCE CHART

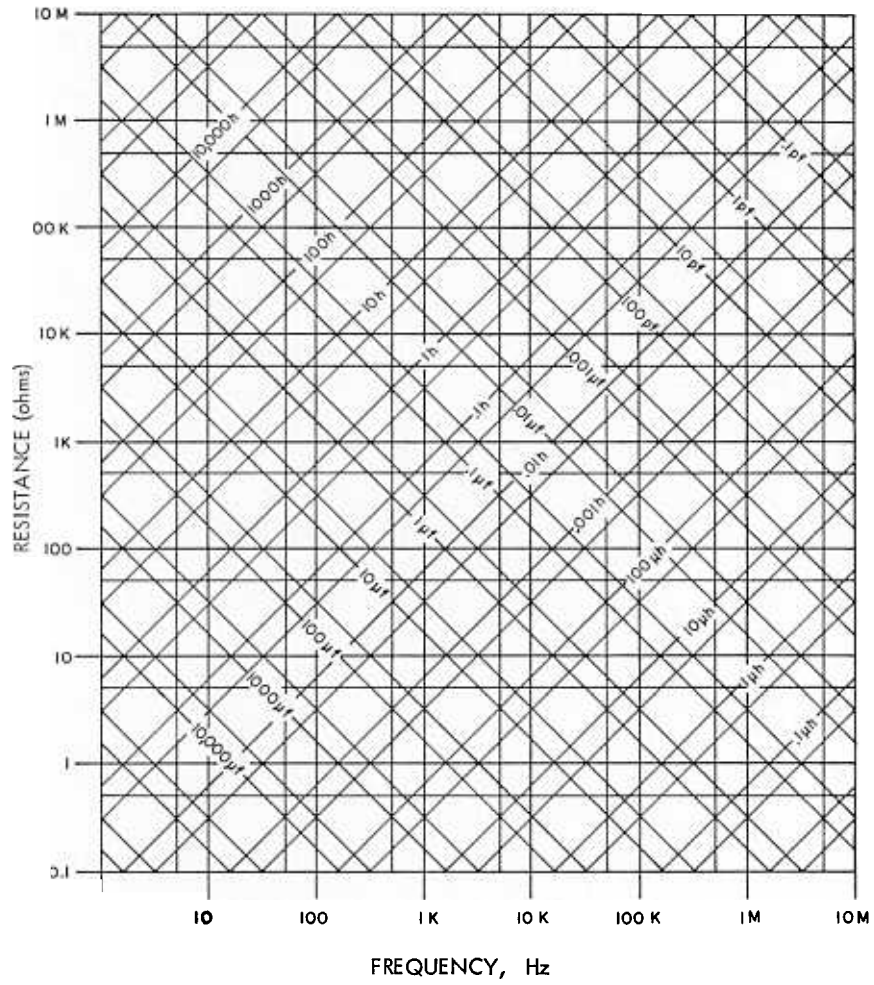

This Page Intentionally Left Blank

DOMESTIC ENGINEERING REPRESENTATIVES

ALABAMA

Huntsville
BCS Associates, Inc.
Phone: (205) 534-1648

ARIZONA

Phoenix
Williams Associates, Inc.
Phone: (602) 254-6085

Tucson
Barr-Brown Research Corporation
Phone: (602) 294-1431

ARKANSAS (See Dallas)

CALIFORNIA

Los Angeles
Instrument Specialists, Inc.
Phone: (213) 665-5181

Santa Clara
Instrument Specialists, Inc.
Phone: (408) 244-1505

CANADA

Downsview, Ontario
Allan Crawford Associates
Phone: (416) 636-4910

Montreal, P. Q.
Allan Crawford Associates
Phone: (514) 739-6776

Ottawa, Ontario
Allan Crawford Associates
Phone: (613) 725-1288

Vancouver, B. C.
Allan Crawford Associates
Phone: (604) 291-7161

COLORADO

Denver
Williams Associates, Inc.
Phone: (303) 388-4391

CONNECTICUT

East Hartford
Measurement Equipment Co., Inc.
Phone: (203) 874-9222

FLORIDA

Orlando
BCS Associates, Inc.
Phone: (305) 425-2764

ILLINOIS

Chicago
Loren F. Green & Associates
Phone: (312) 286-6824

LOUISIANA

New Orleans
BCS Associates, Inc.
Phone: (504) 888-2266

MARYLAND

Silver Spring
QED Electronics, Inc.
Phone: (301) 588-8134

MASSACHUSETTS

Woburn
Measurement Equipment Co., Inc.
Phone: (617) 245-4870

MICHIGAN

Detroit
Sheridan Associates, Inc.
Phone: (313) 358-3333

MINNESOTA

Minneapolis
Loren F. Green & Associates
Phone: (612) 781-1611

MISSOURI

St. Louis
Sheridan Associates, Inc.
Phone: (314) 524-4800

NEW JERSEY

Camden
QED Electronics, Inc.
Phone: (215) 925-8711

NEW MEXICO

Albuquerque
Williams Associates, Inc.
Phone: (505) 255-1638

NEW YORK

Albany
J. A. Reagan Company, Inc.
Phone: (518) 436-9649

Binghamton
J. A. Reagan Company, Inc.
Phone: (607) 723-9661

Mt. Vernon
QED Electronics, Inc.
Phone: (914) 968-2200

New Hartford
J. A. Reagan Company, Inc.
Phone: (315) 732-3775

Rochester
J. A. Reagan Company, Inc.
Phone: (716) 473-2115

NORTH CAROLINA

Greensboro
BCS Associates, Inc.
Phone: (919) 273-1918

OHIO

Cincinnati
Sheridan Associates, Inc.
Phone: (513) 761-5432

Cleveland
Sheridan Associates, Inc.
Phone: (216) 237-9145

Dayton
Sheridan Associates, Inc.
Phone: (513) 277-8911

OKLAHOMA (See Dallas)

PENNSYLVANIA

Pittsburgh
Sheridan Associates, Inc.
Phone: (412) 243-6655

Philadelphia (See Camden, N.J.)

TEXAS

Dallas
Norvell Associates, Inc.
Phone: (214) 357-6451

Houston
Norvell Associates, Inc.
Phone: (713) 774-2568

UTAH

Salt Lake City
Williams Associates, Inc.
Phone: (801) 466-8709

VIRGINIA (See Maryland)

WASHINGTON

Seattle
Instrument Specialists, Inc.
Phone: (206) 767-4260

WASHINGTON, D.C. (See Maryland)

OVERSEAS REPRESENTATIVES

Bart Garfunkel E Hijos S. A.
Bartolome Mitre 1824
Buenos Aires, ARGENTINA
Phone: 45-3827

Kanalec Imports Pty. Ltd.
49 Essex Road
Mt. Waverley, Victoria, AUSTRALIA
Phone: Melbourne: 277 2818
Sydney: 318 2443
Adelaide: 232 703

Dipl. Ing. Peter Marchetti
Sales and Service
A-1060 Wien, Capistrangasse 3
Vienna, AUSTRIA
Phone: 57 82 30

Delta Equipment s.a.
28, rue du Tabellion
Bruxelles 5, BELGIUM
Phone: 02/38.40.76

Instrumentacion
Henrik A. Langebaek & Cia. Ltda.
Carrera 7 No. 48-59
Apartado Aereo 6287
Bogota 1, D.E., COLOMBIA
Phone: 45 78 06
45 35 46

V. H. Pims
129, Sydvestvej
2650 Glostrup, DENMARK
Phone: (01) 96 88 44

Suministros Tecnicos Ltda.,
Box 259-4492, Guayaquil
Calle Rumichacco 825-27, ECUADOR
Phone: 12-419

General Test Instruments Ltd.
Gloucester Trading Estate
Mucclestone, Gloucester, ENGLAND
Phone: Gloucester 67154

Noras & CO OY
Fabriintieku 32
Helsinki 10, FINLAND
Phone: 13360

Societe S.E.P.T.A.
13, rue de Tiquetonne
75 - Paris 2e - FRANCE
Phone: 236-37-45

Dipl. Ing. Ernst Fay
8 Munchen 2
Horemannstrasse 28
Munich, GERMANY
Phone: 0817/516956

Greek Electronics Company Ltd.
6, Kriezotou Street
Athens, 134, GREECE
Phone: 625.469

Air-Parts International N.V.
Electronics Department
149, Hoogweg
Ryswyk (Z.H.) HOLLAND
Phone: (070) 989292

Bacom Electronics Co. Ltd.
74, Nazoua Blvd.
P.O. Box 6170
Tel-Aviv, ISRAEL
Phone: 44 32 44, 25 07 52
Service Department 25 77 20

Strumentazione Industriale Regolazioni
Via Balduino 1 n.60
20158 Milano, ITALY
Phone: 376 198 2

Kyokuto Boki Kaisha, Ltd.
7th Floor, New Oremachi Bldg.
4, 2-Chome, Oremachi, Chiyoda-Ku
Tokyo, JAPAN
Phone: (276) 7711

Electro Promociones Internacionales, S.A.
Lucerna Num. 58
MEXICO 6, D.F.
Phone: 35-41-02

W. & K. McLean, Ltd.
P.O. Box 3097
103-105 Felton Mathew Avenue
Auckland, NEW ZEALAND
Phone: 586-000

Hugo Riso A/S
Carl Grandahls Vei 1
P.O. Box 8 Toosen
Oslo 8, NORWAY
Phone: 2325 80

I. and S. Corporation
2nd Floor, Dada Chambers
Bunder Road, P.O. Box 5025
Karachi-2, PAKISTAN
Phone: 223222

TELECTRA
Rua Rodrigo De Fonseca, 103
Lisbon 1, PORTUGAL
Phone: 686072

David Pollock (Pty.) Ltd.
17 Mallet St., Braamfontein
P.O. Box 3108
Johannesburg, SOUTH AFRICA
Phone: 724-8274

DISTESA
Viriato, 52
Madrid-10, SPAIN
Phone: 223 50 73

Amerikanika Teleproduktur AB
Nybohovsgränd 56
P.O. Box 43070
Stockholm 43, SWEDEN
Phone: 18 29 30
18 29 39

Telemeter Electronic AG
Gerechtigkeitsgasse 25
P.O. Box 140
8007 Zurich, SWITZERLAND
Phone: 051-257872

TELEKOM
Engineering Bureau
P.O. Box 376
Karakoy, TURKEY
Phone: 49 40 40

Vibronics Private Limited
4, Kuria Industrial Estate
Agra Road, Ghatkoper
Bombay-77, INDIA
Phone: 551501

BURR-BROWN



P.O. BOX 11400 INTERNATIONAL AIRPORT INDUSTRIAL PARK
TUCSON, ARIZONA 85706 Phone: 502-294-1431 Telex: 910-952-1111
Cable Address: BBRCORP

IMPORTANT NOTICE

Texas Instruments and its subsidiaries (TI) reserve the right to make changes to their products or to discontinue any product or service without notice, and advise customers to obtain the latest version of relevant information to verify, before placing orders, that information being relied on is current and complete. All products are sold subject to the terms and conditions of sale supplied at the time of order acknowledgment, including those pertaining to warranty, patent infringement, and limitation of liability.

TI warrants performance of its products to the specifications applicable at the time of sale in accordance with TI's standard warranty. Testing and other quality control techniques are utilized to the extent TI deems necessary to support this warranty. Specific testing of all parameters of each device is not necessarily performed, except those mandated by government requirements.

Customers are responsible for their applications using TI components.

In order to minimize risks associated with the customer's applications, adequate design and operating safeguards must be provided by the customer to minimize inherent or procedural hazards.

TI assumes no liability for applications assistance or customer product design. TI does not warrant or represent that any license, either express or implied, is granted under any patent right, copyright, mask work right, or other intellectual property right of TI covering or relating to any combination, machine, or process in which such products or services might be or are used. TI's publication of information regarding any third party's products or services does not constitute TI's approval, license, warranty or endorsement thereof.

Reproduction of information in TI data books or data sheets is permissible only if reproduction is without alteration and is accompanied by all associated warranties, conditions, limitations and notices. Representation or reproduction of this information with alteration voids all warranties provided for an associated TI product or service, is an unfair and deceptive business practice, and TI is not responsible nor liable for any such use.

Resale of TI's products or services with statements different from or beyond the parameters stated by TI for that product or service voids all express and any implied warranties for the associated TI product or service, is an unfair and deceptive business practice, and TI is not responsible nor liable for any such use.

Also see: [Standard Terms and Conditions of Sale for Semiconductor Products](http://www.ti.com/sc/docs/stdterms.htm). www.ti.com/sc/docs/stdterms.htm

Mailing Address:

Texas Instruments
Post Office Box 655303
Dallas, Texas 75265

IMPORTANT NOTICE

Texas Instruments and its subsidiaries (TI) reserve the right to make changes to their products or to discontinue any product or service without notice, and advise customers to obtain the latest version of relevant information to verify, before placing orders, that information being relied on is current and complete. All products are sold subject to the terms and conditions of sale supplied at the time of order acknowledgment, including those pertaining to warranty, patent infringement, and limitation of liability.

TI warrants performance of its products to the specifications applicable at the time of sale in accordance with TI's standard warranty. Testing and other quality control techniques are utilized to the extent TI deems necessary to support this warranty. Specific testing of all parameters of each device is not necessarily performed, except those mandated by government requirements.

Customers are responsible for their applications using TI components.

In order to minimize risks associated with the customer's applications, adequate design and operating safeguards must be provided by the customer to minimize inherent or procedural hazards.

TI assumes no liability for applications assistance or customer product design. TI does not warrant or represent that any license, either express or implied, is granted under any patent right, copyright, mask work right, or other intellectual property right of TI covering or relating to any combination, machine, or process in which such products or services might be or are used. TI's publication of information regarding any third party's products or services does not constitute TI's approval, license, warranty or endorsement thereof.

Reproduction of information in TI data books or data sheets is permissible only if reproduction is without alteration and is accompanied by all associated warranties, conditions, limitations and notices. Representation or reproduction of this information with alteration voids all warranties provided for an associated TI product or service, is an unfair and deceptive business practice, and TI is not responsible nor liable for any such use.

Resale of TI's products or services with statements different from or beyond the parameters stated by TI for that product or service voids all express and any implied warranties for the associated TI product or service, is an unfair and deceptive business practice, and TI is not responsible nor liable for any such use.

Also see: [Standard Terms and Conditions of Sale for Semiconductor Products](http://www.ti.com/sc/docs/stdterms.htm). www.ti.com/sc/docs/stdterms.htm

Mailing Address:

Texas Instruments
Post Office Box 655303
Dallas, Texas 75265